

## TECHNICAL STANDARDS FOR DEBRIS FLOW BARRIERS AND BREAKERS

F. RUDOLF-MIKLAU<sup>(\*)</sup> & J. SUDA<sup>(\*\*)</sup>

<sup>(\*)</sup> Federal Ministry for Agriculture, Forestry, Environment and Water Management - Department IV/5  
Torrent and Avalanche Control, Marxergasse 2 - 1030 Vienna, Austria - email: florian.rudolf-miklau@die-wildbach.at

<sup>(\*\*)</sup> University of Natural Resources and Applied Life Sciences - Institute of Structural Engineering  
Peter Jordan Straße 82 - 1190 Wien, Austria - email: juergen.suda@boku.ac.at

### ABSTRACT

Debris flow barriers and breakers protect human settlements, infrastructure and supply lines from torrential disasters by dissipating the energy of debris flow (floods), dosing (filtering) coarse solid components and deflecting the flows from the areas at risk. The function and design of these structures has to follow the principles of the EUROCODE standards. In order to establish a comprehensive “state-of-the-art” for torrent control engineering an interdisciplinary working group (ON-K 256) was established at the Austrian Standards Institute (ASI) in 2006, which develops new technical standards for load models, design, dimensioning and life cycle assessment (technical standard ONR 24800 - series). The paper summarizes the state of development concerning the function and design of debris flow barriers and breakers.

**KEY WORDS:** *debris flow, torrent control, barriers function, technical standards, action and impacts on barriers, design and dimensioning*

### INTRODUCTION

*Torrent control works* includes by definition all kinds of structures, which are realized in a torrent’s catchment or stream bed, in order to stabilize the bed and adjacent slopes, to regulate the discharge of floods, to dose runoff and solid transport, to filter large components (blocks, drift wood), to dissipate the energy of debris flow or to deviate (by-pass) hazardous

flow processes from objects or areas at risk. (BERGMEISTER *et alii*, 2009) Debris floods and debris flow count among the most hazardous processes in torrents and frequently cause severe damage and human casualties. (RUDOLF-MIKLAU, 2009).

Since the beginning of systematic torrent control in Austria 125 years ago barriers are constructed for protection purposes. Until the end of the 1960s, solid barriers were built at the exits of depositional areas to prevent dangerous debris flows from reaching high consequence areas. The development of solid barriers with large slots or slits to regulate sediment transport began with the use of reinforced concrete during the 1970s. In order to dissipate the energy of debris flows debris flow breakers were designed since the 1980s. By slowing and depositing the surge front of the debris flow, downstream reaches of the stream channel and settlement areas should be exposed to considerably lower dynamic impact.

In the past the technological development of these constructions was only steered by the experiences of the engineering practice while an institutionalized process of standardization comparable to other engineering branches was not existent. In future all structures have to be designed and dimensioned according to the EUROCODE standards. This was the reason to establish an interdisciplinary working group (ON-K 256) at the Austrian Standards Institute (ASI), which has managed to develop comprehensive new technical standards for torrent control engineering,



Fig. 1 - Debris breaker in the Rastetzebach torrent in Bad Hofgastein (Salzburg)

including load models, design, dimensioning and life cycle assessment of torrent control works (technical standard ONR 24800 - series). The technical standard series consists of the following parts:

- ONR 24800, Protection works for torrent control - Terms, definitions and classification;
- ONR 24801, Protection works for torrent control - Actions on structures;
- ONR 24802, Protection works for torrent control - Design of structures;
- ONR 24803, Protection works for torrent control - Operation, monitoring, maintenance.

The ONR 24800 and the ONR 24803 were already published. ONR 24802 and ONR 24801 are available as drafts and will be finished in 2010 respectively 2011. These documents are based on and interact with EN 1990 (basic of structural design), EN 1992-1-1 (design of concrete structures), EN 1997-7 (geotechnical design) and the related documents for the Austrian national specifications. The development of these standards was accompanied by the publication of the first comprehensive technical hand-book on torrent control engineering “state of the art” (BERGMEISTER *et alii*, 2009).

## DEBRIS FLOW BARRIERS AND BREAKERS: FUNCTION AND DESIGN

### FUNCTIONAL CLASSIFICATION

Debris flow dams and breakers count among the torrent control works. According to the “classical” principles of torrent control (AULITZKY, 1980; KETTL, 1984), these structures have to be situated as close to the source of hazard as possible and should be designed for the predominant displacement process in order to gain the maximum efficiency.

Torrents are per definition perennially or intermittently running water courses with steep slope, rapidly changing discharge and massive solid transport (debris, bedload, drift wood) at times. Extreme torrential events comprise four definable displacement processes (IVERSON, 1997; HÜBL, 2006; MARCO, 2007):

- floods;
- fluvial solid transport;
- hyper-concentrated solid transport (debris floods) and
- debris flow (stony debris flow or mud-earth flow).

According to MAZZORANA *et alii* (2009) the sequence of a torrent event corresponds to a *process chain* that is triggered by heavy rain or snow thaw, inducing intensive surface runoff, accretive erosion and slope failures in the headwater area of the torrent catchment, transforming into displacement processes downstream and leading to the deposition of debris and drift wood on alluvial fans, flood plains or gravel bars. This paper is focused on the processes of debris floods and debris flow as well as the corresponding protection structures.

As a rule the design of the torrential barriers has to follow its function. (KETTL, 1984) According to ONR 24800:2008 the functions of torrential barriers can be divided in the following functional types:

- Stabilisation and Consolidation;
- Retention;
- Dosing and Filtering;
- Energy dissipation.

Modern protection concepts in torrent control are scenario-oriented and try to optimize different functions in a chain of protections structures (*function chain*). For torrential displacement processes with high concentration of solids the following types of structures are applied (SUDA & RUDOLF-MIKLAU, 2010):

### BARRIER TYPES FOR RETENTION

The retention includes barriers that support the tailback of debris in natural or artificial reservoirs. The retention of debris is the storage of solids behind dams or in artificial basins. For retention small slot barriers are used (Fig. 2).

Retention of solids leads to a more or less permanent deposition of sediments. Retained debris regularly has to be excavated or spilled from the reservoir in order to keep the function effective. This concept is mainly applied if the torrent downstream has no sufficient transport capacity. This type of barrier function is inefficient if directly exposed to debris flow.

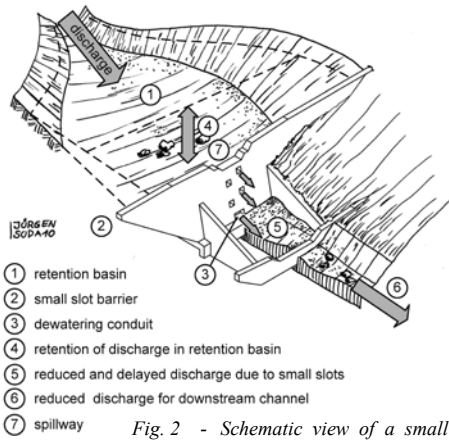

Fig. 2 - Schematic view of a small slot barrier for debris retention

**BARRIER TYPES FOR DOSING AND FILTERING**

The dosing of debris means the temporary retention of coarse bedload during flood peak and the controlled spilling of sediments with descending flood discharge. The intermediate storage of the accumulated material is designed to balance hazard mitigation and a healthy riverine environment.

The filtering includes all kind of barriers that serve the selective retention of coarse solid components like boulders or drift wood from the flow process. Filtering structures have to be designed in a way that fine grained bedload can drift through without being retained. The filtering should be limited to those solids that cause the clogging of bridges and narrows in the lower reach. As dosing/filtering barrier large slot grill barriers are used. This type of barriers controls the transport and deposition processes of sediment, boulders and woody debris (Fig. 3).

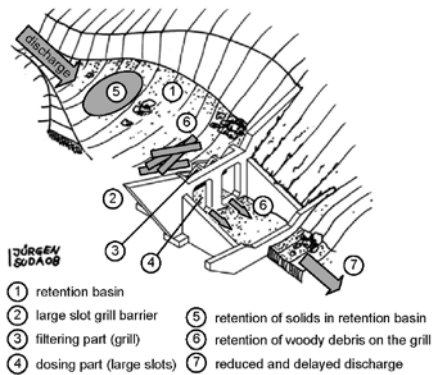

Fig. 3 - Schematic view of a large slot grill barrier for dosing and filtering

**BARRIER TYPES FOR ENERGY DISSIPATION**

Measures with energy dissipation are designed to reduce debris flow energy of debris flows (KETTLE, 1984; JENNI & REITERER, 2002). By slowing and depositing the surge front of the debris flow, downstream reaches of the stream channel and settlement areas are exposed to considerably lower dynamic impact.

The function of dissipation of debris flow energy can either be reached by retarding the flow process (breaking the surge front) or transforming the displacement process. The purpose is reached either by massive constructions that directly impact the debris flow process (“debris breaker”) or by dams that cause a fall and energy dissipation in the spilling pool (“crash dam”).

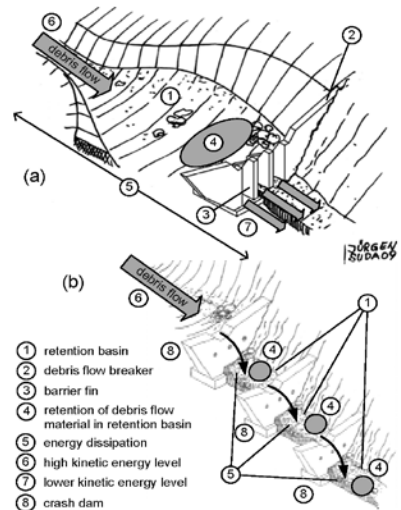

Fig. 4 - Schematic view of (a) a debris flow breaker for energy dissipation and (b) a cascade of crash dams for transformation of debris flow process

The function of debris breaker (Fig. 4a) is reached in combination with a retention basin. The debris flow enters the retention basin and interacts with the dissipation structure. A part of the debris flow is deposited in the basin. Due to the lower inclination of the basins level and the flow resistance of the breaker the kinetic energy of the process will be reduced. Debris flow breakers are built with reinforced concrete and situated as an upper most structure in a function chain. A combination of “debris breaker” with other function at the same barrier should be avoided. If one structure is not sufficient the function may be distributed among several consecutive debris breakers.

Crash dams (Fig. 4b) are as a rule situated on the alluvial fan. If the function of process transformation

cannot be reached by one dam only, a sequence of dams (cascade) may be carried out.

### FUNCTIONAL CATEGORY

According to ONR 24803:2009 the *functional category* has to be determined for each torrent control structure. Two categories of structures can be distinguished depending on the magnitude of consequences of a functional or structural failure (e.g. dam break) for the protection system itself or the area at risk (ONR 24803:2009):

- standard structures;
- key structures.

This classification follows the principles of the ÖNORM EN 1990 depending on the extent of potential damages. Torrential dams can be classified according to the functions listed above. In any case, dams with retaining, dosing, filtering and energy dissipating function count among the *key structures*. Hence the stability and usability of these structures is of major importance for the safety of a whole protection system.

### IMPACT ON BARRIER STRUCTURES BY DEBRIS FLOW: DESIGN CRITERIA TORRENTIAL PROCESSES

The characteristic displacement processes of torrential events (floods, fluvial solid transport, debris floods, debris flow) are definable by physical parameters like the rheology (newtonian/non-newtonian), the volumetric concentration of solids, the density of the liquid-solid-mixture, the kinematic viscosity, the flow velocity or the relative discharge (ratio of total discharge to water discharge).

*Debris flows* are a wide spread mass wasting process in torrential catchments. This term is used for very rapid to extremely rapid flow of saturated debris in a steep channel. The components of these flows are sediments varying from clay to boulder fraction and water. The volumetric concentration of solids ranges from 20 up to more than 60 percent, leading to bulk densities up to 2.5 t/m<sup>3</sup> (JOHNSON, 1970). Depending on the water to sediment ratio different types of debris flows can occur. Based on the bulk mechanical behaviour of the flowing mixture two types of debris flows in alpine environments are distinguished:

- *muddy debris* flow has a wide grain size distribution with a high content of clay-like material.

Due to the “relative” low shear resistance, mud-

dy debris flows can propagate over slopes of 5% minimum. In the field muddy debris flows are recognizable by sharp and well delineated limits of the deposits and randomly distributed boulders and gravel in a finer grained cohesive matrix.

- *granular debris flows* show a wide particle size distribution too, but the content of clay-like material is limited and coarse particles dominate. That is why flow resistance is mainly due to frictional and collisional contacts within the coarse fraction. Energy dissipation is usually much larger than in muddy debris flows, thus granular debris flows require slopes steeper than 15° to flow. In the field deposits of a mass of granular material, from which the fine grained slurry drains easily, and an irregular, chaotic surface give evidence of this type of debris flow.

For torrent processes the frequency-intensity-function shows an emergent behaviour (SCHROTT & GLADE, 2008). That implies a limited predictability of discharge from extrapolations of hydrological data in case a certain threshold value is exceeded. The event disposition of a torrent catchment, defined as the entirety of all conditions essential for the emergence of hazardous processes, consists of the basic disposition comprising all factors immutable over a long range of time (e.g. geology, soils) and the variable disposition, which is the sum of all factors subject to a short-term or seasonal change (e.g. precipitation, land use). If the variable disposition of a torrent catchment is altered in the course of an event (e.g. the water storage capacity of soils is exceeded), the debris potential is erratically increasing resulting in a transition of the predominant displacement process (e.g. solid transport is altered to debris flood) and a non-linear increase of discharge. HÜBL (2010) illustrates this emergent behavior of torrential flows by a multi-stage system status:

- status I comprises fluvial processes (floods, bedload transport)
- status II includes debris flows and debris floods
- status III represents excessive (extreme) events

The design of debris flow barriers and breakers is related to status II and III.

### DESIGN CRITERIA FOR DEBRIS FLOW DAMS

The torrential event represents the entirety of these processes occurring in a temporal, spatial and

Displacement process	Event coefficient (EC)
flood	1,00 – 1,05
(fluvial) bedload transport	1,05 – 1,40
debris flood	1,40 – 3,50
debris flow	> 3,50

Tab. 1 - Process-related event coefficient (EC) for the rough estimation of design flood based on the water discharge

causal relationship and corresponds to a specific probability of recurrence and intensity. The *design event* for the dimensioning of torrent control works is usually determined according to a defined *return period* (e.g. flood with return period of 100 years). Due to the transient behaviour of hyper concentrated flows (debris flood, debris flow) a prediction of discharge based on hydraulic statistics is practically impossible. Consequently flood events of status II and III can be correlated to a certain return period only with restrictions.

For the estimation of *peak discharge* at debris flow regime empirical formulas (MIZUYAMA *et alii*, 1992; RICKENMANN, 1995) based on a simple correlation to bedload (solid transport) can be applied. According to RICKENMANN (2001) the peak discharge ( $Q$ ) [m<sup>3</sup>/sec] of a debris flow can be estimated for granular debris flows with Eqn. (1) and for muddy debris flows with Eq. (2):

$$Q = 0,135 \cdot D^{0,78} \quad \text{Eq. (1)}$$

$$Q = 0,0188 \cdot D^{0,79} \quad \text{Eq. (2)}$$

According to ORN 24802:2010 a rough estimation of the design discharge for debris floods can be done by multiplying the flood discharge with an *event coefficient* (EC). The dimensionless EC is determined with respect to the relevant process according to Tab. 1. The EC takes into account that in the course of hyperconcentrated displacement processes large masses of debris are transported within a short time. The application of this simple model presupposes an assessment of the relevant displacement process in the respective torrent reach.

The characteristic and intensity of the debris displacement has decisive influence on the shape of the flood hydrograph. Excessive displacement processes tend to generate hydrographs with extreme peak discharge but very short transit time, debris flows are characterized by multiple consecutive, steep and short “hydrographs” (comparable to roll waves). (HÜBL, 2010).

There are two traditional simplified models to cal-

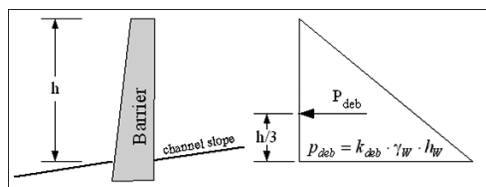

Fig. 5 - Simplified model for debris flow impact on torrential barriers (triangular load distribution and resulting force)

culate *debris flow impact forces*. The model according to LICHTENHAHN (1973) is based on a triangular load distribution and a load increase factor ( $k_{deb}$ ). (Fig. 5)

The second approach is based on mechanical models and rheologic properties of the displacement process. The impact on the structure is shown a constant load distribution (rectangular load distribution). Alternative load models (distribution) are shown in HÜBL & HOLZINGER (2003) and SUDA *et alii* (2009). The relevant actions, their quantification and load models will be arranged in the ONR 24801.

The *peak impact load*  $p_{deb}$  [kN/m<sup>2</sup>] can be defined by Eq. (3). This formulation according to HÜBL & HOLZINGER (2003) bases on laboratory experiments compared with field data. This empirical formulation bases on the peak impact load ( $p_{deb}$ ) [kN/m<sup>2</sup>] the velocity of the debris flow front ( $v$ ) [m/s] and the runoff height ( $hfl$ ) [m]. This model has a scope for FROUDE-values from 1 to 15.

$$P_{deb} = 4,5 \cdot p_{deb} \cdot v^{0,8} \cdot (g \cdot hfl)^{0,6} \cdot 10^{-3} \quad \text{Eq. (3)}$$

For the determination of magnitude (intensity) of debris flows in recent years some physical (e.g. FLO-2D, RAMMS) or empirical models (e.g. TopRun) have been developed, which yield the run-out distance or deposition area (RICKENMANN & SCHEIDL, 2010).

### LOADS ON BARRIER STRUCTURES

Stresses on torrential barriers result from water (hydrostatic, dynamic), earth and debris flow impact. In special cases effects from avalanches, falling rocks and earth-quakes must also be considered. The relevant actions on torrential barriers result from the predominant displacement process in the torrents.

The impacts on torrent control works according to ÖNORM EN 1990 are categorized in *permanent, variable and accidental actions*. According to ONR 24802:2010 accidental impacts are either caused by extreme events exceeding the design event or correlated to processes that are not covered by the system-

atical function of the structure (e.g. earthquakes).

The *proof of the hydraulic capacity* of a torrent control work based on the design discharge comprises the following verifications:

- proof of the capacity of the discharge section (hydraulic capacity has to exceed the design flood taking into account a freeboard);
- proof of the capacity of large openings (slits);
- dimensioning of spilling pool (overflow).

ONR 24802:2010 defines the limit states for the *proof of the stability and serviceability* of the torrent control works and bearing structures. In order to provide these proofs the following impacts have to be taken into account for the design of torrent control works:

- own weight of structure;
- soil pressure;
- water pressure (design water level, water pressure in tension cracks);
- ground water pressure (water pressure at basis);
- dynamic water pressure of design event (flood, debris flow);
- dynamic water pressure exceeding the design event
- water pressure due to unplanned backwater;
- traffic loads.

In specific cases additional impacts by slope failure, rock and snow avalanches, earth quakes or extreme floods have to be taken into account.

### RELEVANT STRESS COMBINATIONS

According to ONR 24802:2010 the relevant impacts for the dimensioning of torrent control structures have to be combined according to the predominant displacement process (status I or II). These characteristic combinations of loads are qualified as standardized *stress combinations (SC)*.

In SC A (Fig. 5), the state before backfill, the hy-

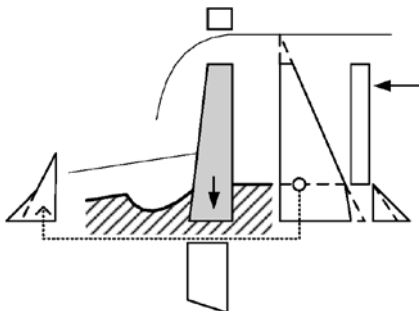

Fig. 6 - Stress combinations for retention, dosing and filtering barriers; according to ONR 24802

drostatic water pressure from the backwater ( $W_{owS}$ ) is acting on the barrier. The specific gravity of the water, depending on the content of bed load in the pure water, ranging from  $\gamma_w = 10$  to  $20 \text{ kN/m}^3$ .

If there is a water flow behind the bottom side of the barriers foundation a reduced hydrostatic water pressure in the soil body can be used. In this stress combination the buoyancy force ( $W_A$ ) is acting on the barriers bottom side. This force reduces the external stability of the barrier. The downstream water pressure ( $W_{uv}$ ) must not be used as a resistance for the barrier.

The highest load on this kind of construction, however, occurs when it is hit by a debris flow. If there is a possibility for such an event stress combinations SC G to L have to be used:

- SC G (Fig. 6) and H - debris flow action on barrier at unfilled storage basin, with/without percolating flow and buoyancy force;
- SC I and J - debris flow action on barrier at partly filled storage basin, with/without percolating flow and buoyancy force;
- SC K and L - debris flow action on barrier at totally filled storage basin, with/without percolating flow and buoyancy force.

Details on the *calculation* of the specific loads and their load distribution are given in BERGMEISTER *et alii* (2009), detailed standards will be included in ONR 24801:2011.

### IMPACT OF EXTREME EVENTS (STATUS III)

Excessive torrential events (status III) as a rule exceed the design criteria for torrent control works. The impact by these extreme events can result in the structural or functional failure of dams although only few cases of dam break are documented in the history of torrent control engineering. Excessive torrential

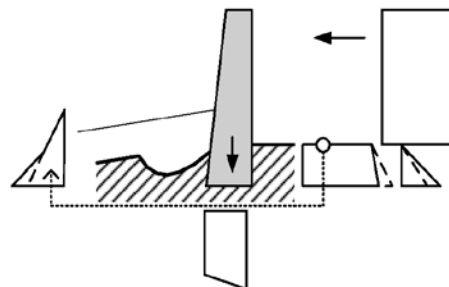

Fig. 7 - Stress combinations for energy dissipation barriers (debris flow breaker); according to ONR 24802

events have to be taken into account with respect to dam safety and the residual risk.

For large dams European standards require that an extreme flood event of a return period of 5.000 (10.000) years can securely overflow the structure. In Austria this regulation applies for dams with a height exceeding 15 meters or reservoirs with more than 500.000 m<sup>3</sup> (BMLFUW, 2009). Torrent dams have to be dimensioned according to these standards if a longer lasting tailback of water has to be taken into account. (ONR 24802:2010) The hydraulic effects and consequences of a dam break can be estimated (calculated) by flash flood models. The failure of reservoirs upstream of steep torrential watercourses may trigger debris flows, which consequently have to be taken into account in a safety concept for flood retention basins.

For “classical” debris flow dams a longer lasting tailback of water is improbable due to the permeable construction and the large openings (slots, slits). The appropriate design for extreme floods is reached by constructive measures such as oversized or double-profiled discharge cross sections.

**DESIGN OF DEBRIS BARRIERS (BREAKERS)**

For the design of debris barriers (breakers) the Ultimate Limit States (ULS) and the Serviceability Limit States (SLS) must be considered. The rules for assessment and design are related to the EUROCODE - standards. The ONR 24802 is based on this concept and gives specific design rules for torrential barriers.

*ULTIMATE LIMIT STATE DESIGN*

The failure types of torrential barriers are related to those of retaining structures. On torrential barriers an external and internal failure can appear (SUDA *et alii*, 2010). The following Ultimate Limit States must be considered:

External stability:

- EQU: equilibrium limit state;
- GEO: geotechnical limit state, failure or excessi-

Variation in time of action			Ultimate limit states		
			Design situations		
Permanent	favourable	$\gamma_{G,sup}$	DS1	DS2	DS3
	unfavourable	$\gamma_{G,inf}$	1,35	1,20	1,00
Variable	favourable	$\gamma_{Q,sup}$	1,50	1,30	1,00
	unfavourable	$\gamma_{Q,inf}$	0	0	0
Shrinkage of concrete		$\gamma_{SH}$	1,00	1,00	1,00

DS1: Persistent Design Situation, DS2: Transient Design Situation, DS3: Accidental Design Situation

Tab. 2 - Partial safety factors for actions and STR/GEO assessment, according to ONR 24802

ve deformation of the ground (sliding at the base, toppling, bearing resistance failure of the soil below the base, loss of overall stability);

- UPL: uplift limit state;
- HYD: heave limit state.

Internal stability:

- STR: structural failure, failure or excessive deformation of the structure or one of its elements (bending, shear and stability failure).

For assessments, torrential dams are mostly treated like retaining structures. For ULS - design the semi probabilistic assessment concept is used. The models for assessment and the values of the partial safety factors for actions and resistances for GEO, UPL, EQU and HYD limit states are equal to ÖNORM B 1997-1-1. For reinforced concrete units assessment in the STR limit states the partial safety factors for actions are given in Tab. 2.

The values of the partial safety factors for the building material resistances (e. g. concrete, steel, timber) depend on the material characteristics, the regarded limit state and the design situation (DS). The partial safety factors for structures material resistances are given in EN 1992-1-1 and ÖNORM B 1992-1-1, EN 1993-1-1 and ÖNORM B 1993-1-1 and EN 1995-1-1 and ÖNORM B 1995-1-1.

*SERVICEABILITY LIMIT STATE DESIGN (SLS)*

For SLS - design the following analyses are necessary:

- process serviceability design, according to the functional type;
- limitation of settlements ÖNORM B 1997-1-1;
- limitation of crack widths ÖNORM EN 1992-1-1, chapter 7.3 for reinforced concrete barriers

The limit values for crack widths  $w_{max}$  in reinforced concrete structures, in dependence of the exposition classes which are defined in the ÖNORM B 1992-1-1, Tab. 4, are to be kept. In hydraulic engineering, the crack widths have to be limited to 0.25 mm for

Requirements due to durability (exposition classes)	Additive requirements due to serviceability	$w_{max}$	Examples
XC2, XC3, XC4, XD1, XD2, XD3	Impermeability to water not necessary	0.3	Lateral supporting wall, grill abutment
	Impermeable to water	0.25	Dam body and wings, foundation slab

Tab. 3 - Recommended maximum crack width ( $w_{max}$ ) for torrential barriers, according to ONR 24802

Requirements	Regulations for reinforcement
Impermeable to water	$A_{s \min} = 0,001 \cdot A_c \leq 25 \text{ cm}^2/\text{m}$ <sup>1)</sup>
1 permeability not necessary	$A_{s \min} = 0,0006 \cdot A_c \leq 15 \text{ cm}^2/\text{m}$ <sup>1)</sup>
For all cases	$d_s = 10 \text{ mm}$ $s = 15 \text{ cm}$ <sup>1)</sup>

1) This reinforcement is per side and axis

Tab. 4 - Recommended minimum reinforcement for torrential barriers, according to ONR 24802

waterproof reinforced concrete construction works. The maximally permissible crack widths for torrential barriers are given in Tab. 3.

For durability and serviceability reasons a minimum reinforcement ( $A_{s \min}$ ) near to the surface for all concrete members (Tab. 4) is requested. This minimum reinforcement is given as fraction of the concrete cross section ( $A_c$ ).

## DISCUSSION AND CONCLUDING REMARKS

The technical standards of the ONR 24800-se-

ries constitute a new dimension in torrent control engineering. The application of these regulations will favour the efficiency and cost-effectiveness of protection structures and secure a high standard of quality concerning the functionality, stability and safety of barrier structures. After the completion of the new Austrian standards a phase of testing and evaluation will help to gather experiences with the practical application of these regulations. In addition a process of international implementation of these standards was started with Bavaria and Slovenia participation in the development process.

## ACKNOWLEDGEMENTS

The authors thank the Federal Ministry of Agriculture, Forestry, Environment and Water Management, the Austrian Service for Torrent and Avalanche Control and the Austrian Standards Institute for the support of this research and development process.

## REFERENCES

- AULITZKY H. (1980) - *Preliminary Two-fold Classification for torrent cones*, Proceedings of Interpraevent Conference, 4: 243-256.
- BERGMEISTER K., SUDA J., HÜBL J. & RUDOLF-MIKLAU F. (2009) - *Schutzbauwerke gegen Wildbachgefahren*. Ernst und Sohn, Berlin.
- BMLFUW (2009) - *Leitfaden zur Hochwassersicherheit von Stauanlagen*. Bundesministerium für Land- und Forstwirtschaft, Umwelt und Wasserwirtschaft; Technische Universität Wien, Institut für Wasserbau und Ingenieurhydrologie (in German).
- HÜBL J. (2006) - *Vorläufige Erkenntnisse aus 1:1 Murenversuchen: Prozessverständnis und Belastungsannahmen*. In: FFIG, G. REISER (Hrsg.), *Geotechnik und Naturgefahren: Balanceakt zwischen Kostendruck und Notwendigkeit*. Institut für Geotechnik, BOKU Wien, Geotechnik und Naturgefahren, 19.10.2006, Wien (in German).
- HÜBL J. (2010) - *Hochwässer in Wildbacheinzugsgebieten*. Wiener Mitteilungen (in print).
- HÜBL J. & HOLZINGER G. (2003) - *Entwicklung von Grundlagen zur Dimensionierung kronenoffener Bauwerke für die Geschiebemanagement in Wildbächen: Kleinmaßstäbliche Modellversuche zur Wirkung von Murbrechern*, WLS Report 50 Band 3. Im Auftrag des BMLFUW VC 7a (unveröffentlicht). Wien: Institut für Alpine Naturgefahren, Universität für Bodenkultur
- IVERSON R.M. (1997) - *The physics of debris flows*. Reviews of Geophysics 35, American Geophysical Union: 245-296.
- JENNI M. & REITERER A. (2002) - *Debris flow management with crash dam construction*. Journal of Torrent, Avalanche, Landslide and Rock Fall Engineering, 148: 11-19.
- JOHNSON A.M. (1970) - *Physical processes in geology*. San Francisco: Freeman and Cooper.
- KETTL W. (1984) - *Vom Verbaunungsziel zur Bautypenentwicklung*. Wildbachverbaunung im Umbruch. Wildbach- und Lawinenverbaunung, 48: 61-98.
- LICHTENHAHN C. (1973) - *Die Berechnung von Sperren in Beton und Eisenbeton*. In: Kolloquium über Wildbachsperren, Mitteilungen der forstlichen Bundesversuchsanstalt Wien, Heft, 102 S.91-127
- MARCO F. (2007) - *Torrential Processes*. In: CAMPUS S, FORLATI F., BARBERO S. & BOVO S. (eds.): *Evaluation and Prevention of Natural Risks*. Taylor and Francis/Balkema: 169-199.
- MAZZORANA B., FUCHS S. & HÜBL J. (2009) - *Improving risk assessment by defining consistent and reliable system scenarios*. Nat. Hazards Earth Syst. Sci., 9: 145-159.
- MIZUYAMA T., KOBASHI S. & OU G. (1992) - *Prediction of debris flow peak discharge*. Proc. Int. Symp. Interpraevent, Bern, Switzerland, 4: 99-108.
- PROSKE D., KAITNA R., SUDA J. & HÜBL J. (2008) - *Abschätzung einer Anprallkraft für murenexponierte Massivbauwerke*. Beton und Stahlbetonbau, 12: 803-811.



- RICKENMANN D. (1995) - *Beurteilung von Murgängen*. Schweizer Ingenieur und Architekt, **48**: 1104- 1108 (in German).
- RICKENMANN D. (2001) - *Estimation of debris-flow impact an flexible wire rope barriers*. Swiss Federal Research Institute WSL.
- RICKENMANN D. (2003) - *Methode zur Beurteilung von Murgängen; ETALP - MURGÄNGE V2.2*; Universität für Bodenkultur Wien.
- RICKENMANN D. & SCHEIDL C. (2010) - *Modelle zur Abschätzung des Ablagerungsverhaltens von Murgängen*. Wasser Energie Luft, **102**: 17-26 (in German).
- RUDOLF-MIKLAU F. (2009) - *Naturgefahren-Management in Österreich*, Nexis Lexis Orac, Wien.
- SCHROTT L. & GLADE T. (2008) - *Frequenz und Magnitude natürlicher Prozesse*. In: FLEGENTREFF & GLADE T. (eds.): *Naturrisiken und Sozialkatastrophen*. Spektrum Akademischer Verlag Springer: 134-150 (in German).
- SUDA J., HÜBL J. & BERGMEISTER K. (2010) - *Design and Construction of high stressed Concrete Structures as Protection Works for Torrent Control in the Austrian Alps*. In: Proc. of the 3<sup>rd</sup> fib international Congress, Washington, USA.
- SUDA J. & RUDOLF-MIKLAU F. (2010) - *Standards for design and maintenance of torrential barriers*. 8<sup>th</sup> ICOLD European Club Symposium, Innsbruck, Austria (in press).
- SUDA J., STRAUSS A., RUDOLF-MIKLAU F. & HÜBL J. (2009) - *Safety Assessment of Barrier Structures*. Structure & infrastructure engineering, **5**: 311-324.