

PATTERNS OF FLOWER AND INFLORESCENCE ARCHITECTURE IN *CROCUS* L. (IRIDACEAE)

VLADIMIR V. CHOOB

Plant Physiology, Department of Biology, Moscow State University, Vorobjevy Gory, Russia

ABSTRACT - In *Crocus*, inflorescence characters are widely used for intrageneric systematics. Despite of this, spatial relations of flowers and involucral leaves are poorly documented. The focus of our study was the paracladial region and spatha leaves of *C. flavus* and *C. vernus*. The first indication of the lateral position of the flower in both species was zygomorphy of the androecium and gynoecium. In other *Iridaceae* (*Freesia*, *Gladiolus*) stamens also have unequal length. The homeotic substitution of stamens by petaloid organs makes zygomorphy in *Freesia* more distinct, thus we propose that flowers have a latent genetic program for zygomorphization. The second indication is the bidentate shape of bracts and bracteoles in *C. flavus* and tridentate structure of the basal involucre in *C. vernus*, which we interpret as a fusion of the foliage leaf and the prophyll of the inflorescence. The shape and the position of the lateral inflorescences (paracladia) were also investigated. In *C. flavus*, corms often born several paracladia in the axils of the green leaves, whereas in *C. vernus* we found a single paracladium in the axil of a scale inside the basal involucre. The correlation between the number of paracladia, their position and the spathe leaves were discovered. We propose to use these characters for the definition of two subgenera in *Crocus*.

KEY WORDS – *Crocus*, inflorescence, bract, bracteole, prophyll

INTRODUCTION

Flowers in *Crocus* L. were long assumed to be terminal, but this interpretation of inflorescence morphology was recently revised by Mathew (1980), who worked out a new terminology. Nevertheless, the structure of the *Crocus* inflorescence still requires further analysis, especially the morphology of the paracladial region and the position of lateral inflorescences in the axial system of the plant.

Inflorescence structure is an important character of infrageneric systematics in *Crocus* (Maw, 1886; Fedchenko, 1935; Mathew, 1980). Herbert (1846) grouped all the species of the genus using presence or absence of the spathe at the inflorescence base (cited by Kapinos, 1965). This was developed by Maw (1886), who established two subgenera: *Involucrati* Maw with a basal spathe, and *Nudiflori* Maw with no basal spathe. More detailed analysis of the spathal leaves (Mathew, 1980) revealed

that the basal leaf in *Involucrati* is a prophyll. Correspondingly, Mathew (1980) proposed the use of the terms ‘prophyll’, ‘bract’ and ‘bracteole’ for the leaf-like structures surrounding the flower. Only a few European species of *Crocus* species have the complete series of these organs (*C. cambessedessii* Gay and *C. imperati* Ten. subsp. *imperati*). Most *Crocus* species lack prophylls (e.g. *C. flavus* Weston, *C. chrysanthus* [Herbert] Herbert, *C. angustifolius* Weston) or bracteoles (e.g. *C. vernus* L., *C. tommasinianus* Herbert, *C. sativus* L.). *C. tommasinianus* and *C. sativus* correspond to the earlier classification of Maw (1886) to *Involucrati*.

FLOWER DIAGRAM

In order to elucidate *Crocus* morphology, we start with a basic description of the flower. As summarised by Eichler (1875), the *Crocus* flower is trimerous, as in most monocotyledons; the actinomorphic perianth is composed of two alternate whorls, three stamens alternate with the inner tepals, whereas the carpels are opposite the stamens. Because of the whorl alternation principle, Eichler (1875), specifying *Crocus*, proposed that the inner stamen whorl is lost in *Iridaceae*. This alternation principle can also be applied to the organs outside the flower. In *Gladiolus* L. the bracteole alternates with the outer perianth whorl (the bracteole in this case is the prophyll of the lateral axis, developed in the axil of the bract). Thus, using data on flower organ position, we can calculate the position of the bract nearest to the flower.

UNEQUAL STAMEN LENGTH IN *CROCUS* FLOWERS

In early development of the *Crocus* flower, one of three stamens begins to elongate earlier than the other two (Kapinos, 1965). Kapinos’s interpretation of this was that the longer stamen was a member of the outer whorl, whereas the other two were from the inner whorl. However, this interpretation is discordant with stamen position. Moreover, we can observe the corresponding elongation of the stigma lobe opposite the longer stamen, so a more likely interpretation is that the flower is zygomorphic.

ZYGOMORPHY IN *IRIDACEAE*

Eichler (1875) reviewed floral morphology for the majority of Angiosperm families. His main object was the median position of the plane of symmetry of the flower; i.e. the plane of zygomorphy including the main axis and the median vein of the bract. Among the exceptions to this rule, Eichler (1875) cited *Fumariaceae*, with a transverse plane of zygomorphy (perpendicular to the median plane) and *Iridaceae*, where different genera have a sixth or a third angle of deviation of the floral zygomorphy plane from the median (Fig.1). I term this situation ‘tangential zygomorphy’, which is apparently unique to *Iridaceae*. According to our observations on cultivated *Gladiolus* hybrids, in early development the flower is actinomorphic, but at the time of elongation of the inflorescence stalk, “zygomorphization” occurs in the lower flowers: one of the stamens elongates faster than the other two, coloured spots are initiated in the lower lip of the perianth, and

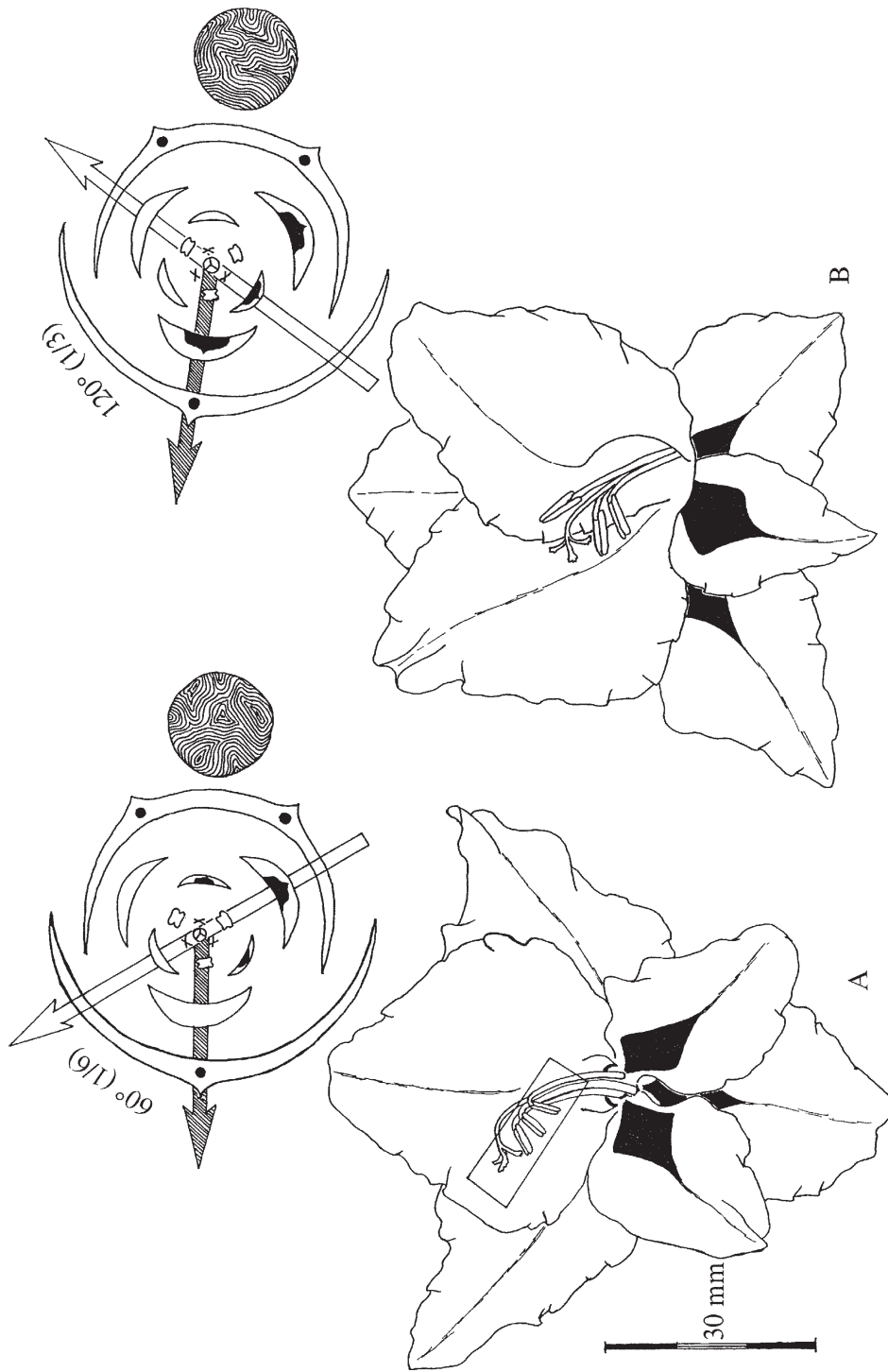

Figure 1 - Flower diagram and two patterns of zygomorphy in *Iridaceae*. The vector of zygomorphy is the white arrow, the median vector shaded. Black spots on the perianth mark the position of the contrastly coloured tepals of the lower lip. Downwards - the flower shapes. A - The angle of divergence is 60° (1/6): characteristic of *Gladiolus* and probably *Watsonia* Mill. and *Babiana* (as reported by Eichler, 1875). B - The angle of divergence is 120° (1/3): this occurs as a less frequent variant in cultivars of *Gladiolus hybridus*.

finally all the flower whorls have more or less pronounced zygomorphy. In the gynoecium zygomorphy is manifested as unequal lobes of the stigma and (mainly) as curvature of the style towards the “upper” side of the flower. In the androecium there is unequal stamen (filament) length. The perianth may be curved and have specific distribution of contrasting spots, and different widths and lengths of “lower” and “upper” tepals.

On the other hand, in *Crocus* only stamen length is zygomorphic, making true zygomorphy questionable in this genus. *Freesia* Klatt. flowers also have only weak zygomorphy. The perianth is almost actinomorphic, and only stamen length and deformation of the style indicate zygomorphy, as in *Crocus*. *Freesia* is a convenient model plant, because it has multiple double cultivars, so we can question whether stamen zygomorphy is only occasional, or whether *Freesia* really has a latent genetic programme for zygomorphy. In double cultivars stamens are totally or partially transformed into petal-like organs. If the new perianth whorl in the position of the stamens was actinomorphic, we could not give much credit to stamen length. If the androecium is really zygomorphic, new tepals should also be zygomorphic, unlike ‘normal’ tepals in *Freesia*. Our observations revealed zygomorphy in the organs in the androecial whorl (Fig. 2). The “upper” stamen had wider and more symmetric petaloid lobes and a reduced anther. The “lower” stamen usually retained its anther and had asymmetric distribution of the petaloid tissues: narrow lower and widened upper lobes. Consequently, I conclude that stamen length is an important character, indicative of latent “zygomorphization”. From an evolutionary viewpoint this can be viewed in two ways: (1) The ancestor of the species (genus) was zygomorphic, but complete “zygomorphization” is partially lost. (2).The ancestor was actinomorphic, and the weak zygomorphic pattern is the first step towards a completely zygomorphic flower.

In any case, a zygomorphic flower never occurs in the terminal position, so the *Crocus* flower has latent zygomorphy and is not terminal.

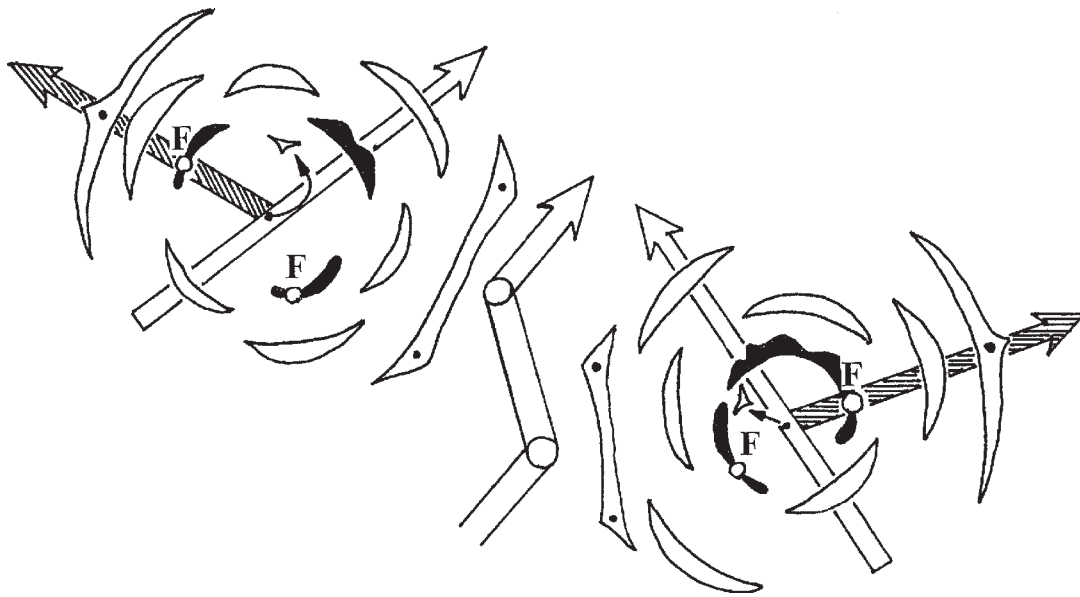

Figure 2 - Zygomorphy in the stamen-like organs in double *Freesia refracta* (Jacq.) Klatt. Petaloid organs in the position of stamens are filled black. F- positions of stamen filaments. In the centre, the position of the stigma at anthesis.

DEVELOPMENTAL AND SHAPE POLYMORPHISM IN *C. FLAVUS*
AND *C. CHRYSANTHUS*

Further support for a lateral position of the flower in *Crocus* can be obtained from the shape of bract and bracteole (Choob and Kuznetsova, 1999). As mentioned above, some species of *Crocus* have a bract and bracteole, others have a prophyll and bract (no bracteole) and a few species have all three organs. For analysis of the former case (bract and bracteole), I used commercial corms of *C. flavus* cv. 'Yellow Mammoth', *C. chrysanthus* Herb. cv. 'Cream Beauty', *C. sieberi* Gay cv. 'Tricolor', *C. ancycensis* (Herb.) Mawo cv. 'Golden Bunch' and *C. angustifolius*, *C. tauricus* Stev. and *C. speciosus* Bieb. from Nikita Botanical Garden (Yalta, Ukraine). *C. flavus* was the model species for the detailed analysis, whereas in others were used to check the data.

In dormant corms of *C. flavus*, both bract and bracteole have a distinct bidentate apex. The bract base is sheathing, whereas the bracteole base is open (semisheathed; Fig.3). During development the shape of the bract changes

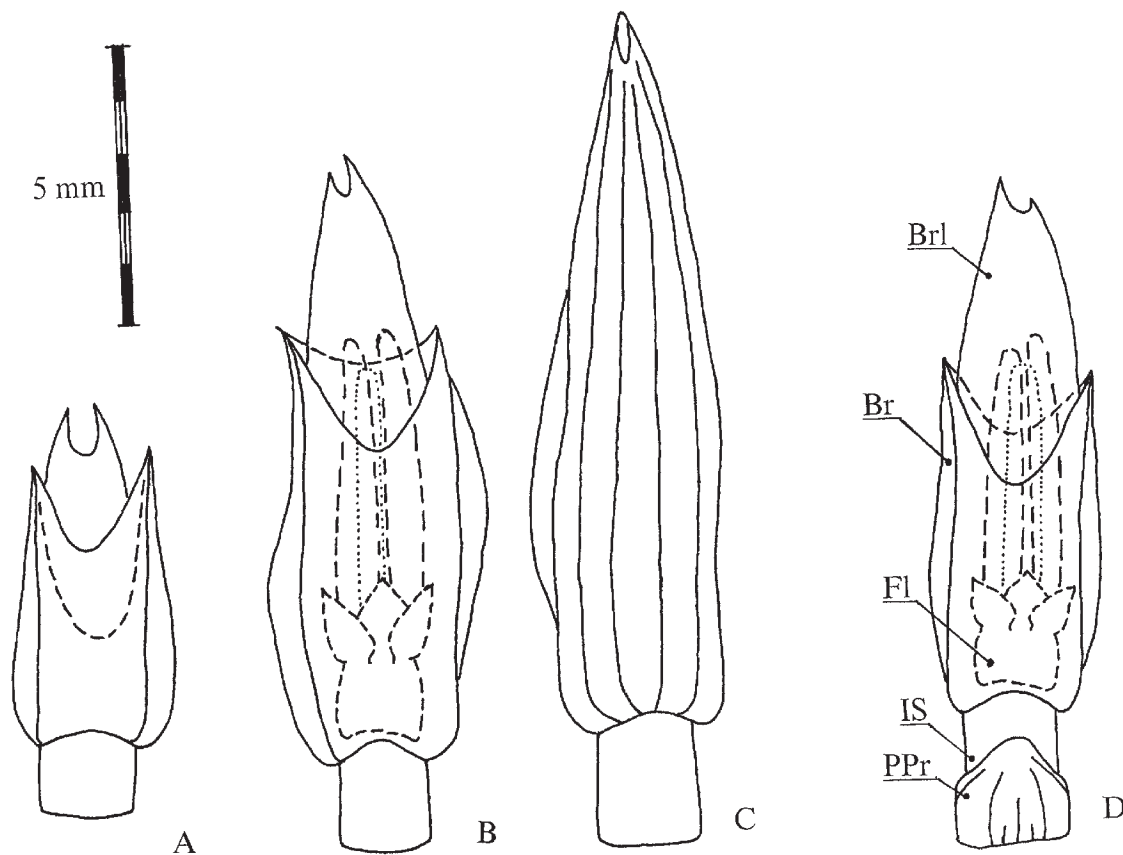

Figure 3 - Organ shape in *Crocus flavus* Weston cultivar 'Yellow Mammoth' (by Choob and Kusnetsova, 1999). A-C. The main inflorescence development, dorsal view. D. Paracladium, dorsal view. IS - inflorescence stalk; Br - bract; Brl - bracteole; PPr - prophyll of paracladium; Fl - flower, covered with bract and bracteole. The shortest (ventral) stamen is drawn with a dotted line.

dramatically. Its apex remains bidentate as long as the bract is smaller than the flower. Further growth leads to fusion of the teeth and loss of the bidentate structure (Fig. 3). At anthesis the bract is always disturbed by the flower, and the apex undergoes secondary changes. The bracteole does not enclose the flower, so the apical structure remains two-toothed even at anthesis. In some flowers one of the bracteole teeth may be reduced. These data show that both bract and bracteole are similar to prophylls in their shape. Consequently, further evidence for the lateral position of the flower in *Crocus* comes from a study of organ shape.

“PHANTOM” METHOD

Prior to discussion of the spatial relations between leaves, some introductory notes are necessary on the method used for the interpretation of diagrams (for details see Choob, 1998; Choob and Kuznetsova, 1999). Eichler (1875) proposed a method of diagrams for description of flower morphology. As the main tool he used the ‘*Typenmethode*’, i.e. a method for comparison of closely related taxa. If an organ occurs in some taxa, but is absent in others, we can assume it to be reduced. Eichler proposed two methods of organ reduction: (1) Abortion: the organ is initiated, but does not develop, although some reminiscent structure may be observed in organ position. (2) Ablasty: no organ initiation. In *Typenmethode* one can only reach a conclusion after observation of many plants of related taxa, followed by generalisation of the diagram and comparison of this “experimental” diagram with the plant to be analysed. If the taxonomy or morphology are not sufficiently well-known, *Typenmethode* gives several results for the same family, explained as polymorphism. This method is therefore not convenient if it is impossible to obtain many plants from different taxa. I have therefore modified it in order to obtain data for a single species.

Organs of the seasonal growth unit were sequentially removed and documented in diagrams, which were formally transformed into longitudinal branching schemes, using the following rules: (1) Phyllotaxy is 2/5 for foliage leaves and 1/2 for cataphylls and bracts. (2) The leaf series of every lateral axis is initiated with a single prophyll in an adaxial position. If these rules were not sufficient for the model, it was assumed that some leaves have been reduced or lost. Thus schemes were supplemented with ‘phantoms’, although schemes containing a minimum of phantom leaves were preferred.

SPATIAL RELATIONS OF BRACT AND BRACTEOLE IN *C. FLAVUS*

The angle of divergence between the bract and the uppermost foliage leaf varies from 20° to 45°. If the 2/5 phyllotaxis of the main axis were continued, the bract would occur on the opposite side (Fig.4). The bract and bracteole are parallel in their early development (Fig.3). In some cases the bracteole is slightly rotated. Their angle of divergence is almost 0° (360°). The outer perianth always alternates with the bracteole, which makes their angle of divergence 180° (1/2).

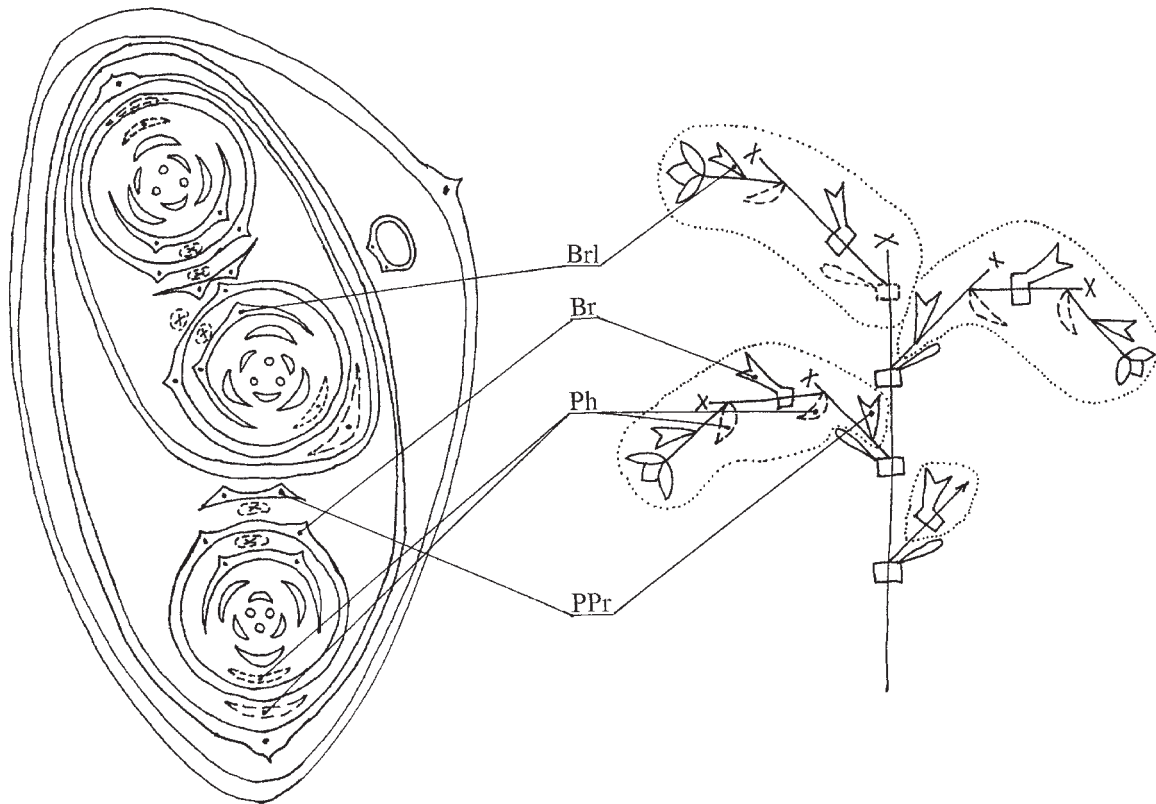

Figure 4 - Diagram of inflorescence in *Crocus flavus* (Nudiflori) and its formal interpretation (by Choob and Kusnetsova, 1999). Br - bract; Brl - bracteole; PPr - prophyll of paracladium; Ph - phantom leaves.

The main axis bears foliage leaves with $2/5$ phyllotaxis. The uppermost leaf is phantom 1. In the axil of phantom 1 a new shoot is initiated, containing prophyll 1 (bract) and a second leaf (phantom 2). Phyllotaxis is $1/2$. The axis of the third order is placed in the axil of phantom 2 and bears prophyll 2 (bracteole) and the flower. Phyllotaxis is $1/2$.

In the position of phantom 2, I once observed a small scale, indicating that phantom 2 is either a case of ablasty (in most cases) or abortion (in the very rare cases with a scale).

PARACLADIAL STRUCTURE IN *C. FLAVUS*

Initiation of one to several paracladia in axils of foliage leaves often occurs in *Crocus*, especially in cultivated material. A small scale (usually with an open base) occurs at the base of the paracladium, in the adaxial position relatively to the main axis. The scale is more or less bidentate, but in early development this character is not well-developed (Fig. 3). The shape of the scale is variable and depends on the species

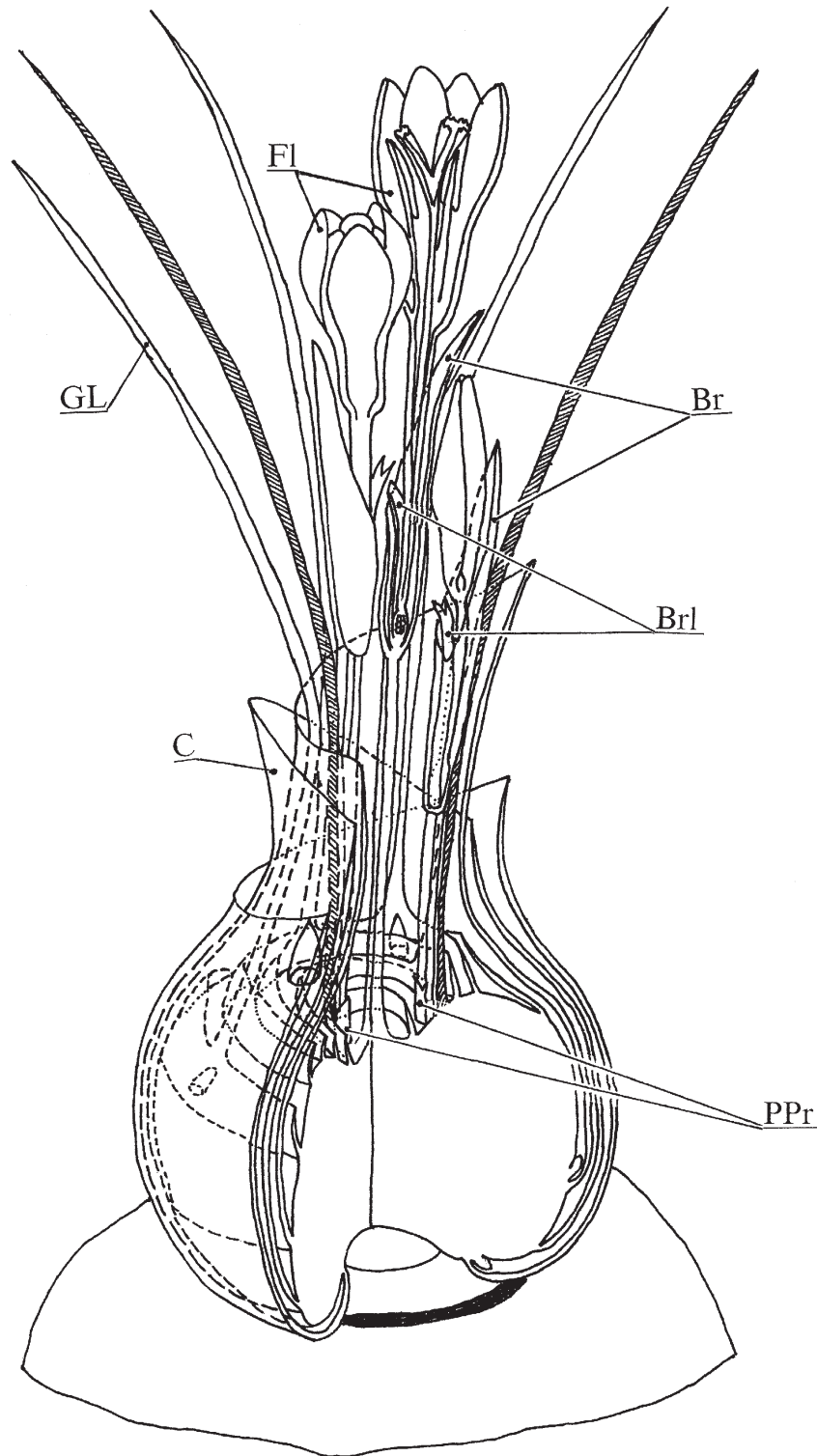

Figure 5 - Complete organ map of *Crocus flavus* (Nudiflori). The structure of the bracts disturbed by the flowers (by Choob, 1995). Br - bract; Brl - bracteole; C - cataphyll; GL - foliage leaf; Fl - flower; PPr - prophyll of paracladium.

and even on the cultivar or clone. Sometimes it is impossible to detect teeth on the scale, which has no distinct keels or main veins. Despite this, comparative data on position and shape in all the *Crocus* species and clones analysed support the interpretation of the scale as a prophyll.

The angle of divergence between the prophyll and the bract appears to be close to 0° (360°). The spatial relations of the uppermost organs are as in the main inflorescence. Correspondingly, the minimal axial scheme of paracladial region is close to the terminal group of organs (Figs.4, 5). The main axis bears foliage leaves with $2/5$ phyllotaxis. The axils of the uppermost one to several leaves are occupied with the axis of the second order. The 2nd order axis bears a small prophyll and a phantom 1 (phyllotaxis is $1/2$). In the axil of phantom 1 a new shoot (3rd order) is initiated. Its leaf series contains prophyll 1 (bract) and another leaf: phantom 2. Phyllotaxis is $1/2$. The axis of the 4th order is in the axil of phantom 2 and bears prophyll 2 (bracteole) and the flower. Phyllotaxis is $1/2$.

DEVELOPMENTAL AND SHAPE POLYMORPHISM STUDY IN *C. VERNUS* AND *C. TOMMASINIANUS*

C. vernus and *C. tommasinianus* belong to the (prophyll + bract) group, i.e. to subgenus *Involucrati* Maw. They have their own pattern of inflorescence architecture, different from that described above. For analysis I used commercial corms of *C. vernus* cvs. "Joan of Arc", "Flower Record", "Pickwick", "Remembrance" and others. I also obtained several plants of *C. tommasinianus* from the collection of the Botanical Garden of Moscow State University. Unfortunately, in *C. vernus* the bract has no any distinct keels or teeth in early development, so I could not place it adequately on diagrams or draw any conclusions about its morphology.

In *C. vernus* and *C. tommasinianus* the basal involucre (prophyll of Mathew, 1980) has a tridentate shape (Fig.6), which is especially pronounced in *C. tommasinianus*. One of the teeth resembles foliage leaf lamina and continues the phyllotaxy of the main axis (144°), whereas the other two teeth are opposite the first (Fig.7). This leads to the conclusion that the basal involucre is a complex organ, composed by a fused foliage leaf and prophyll of the inflorescence.

PARACLADIAL STRUCTURE IN *C. VERNUS*

Initiation of a single paracladium occurs commonly in both *C. vernus* and *C. tommasinianus*, but further development is under environmental control. I observed an aborted lateral inflorescence in the position of the unpaired lamina-teeth inside the involucre. Nevertheless, the paracladium is not in the axil of the involucre leaf, because sometimes a small scale is visible at the base of the paracladium (Fig. 8). Paracladia have their own prophylls, which normally possess two teeth. I have not observed any paracladia of the third order inside these prophylls. The innovation bud is always outside the involucre, situated in the axil of the foliage leaf nearest to the inflorescence.

The inflorescence structure of *C. vernus* is as follows (Figs. 7, 8). The main axis bears foliage leaves with phyllotaxis $2/5$. The axil of the uppermost leaf is occupied

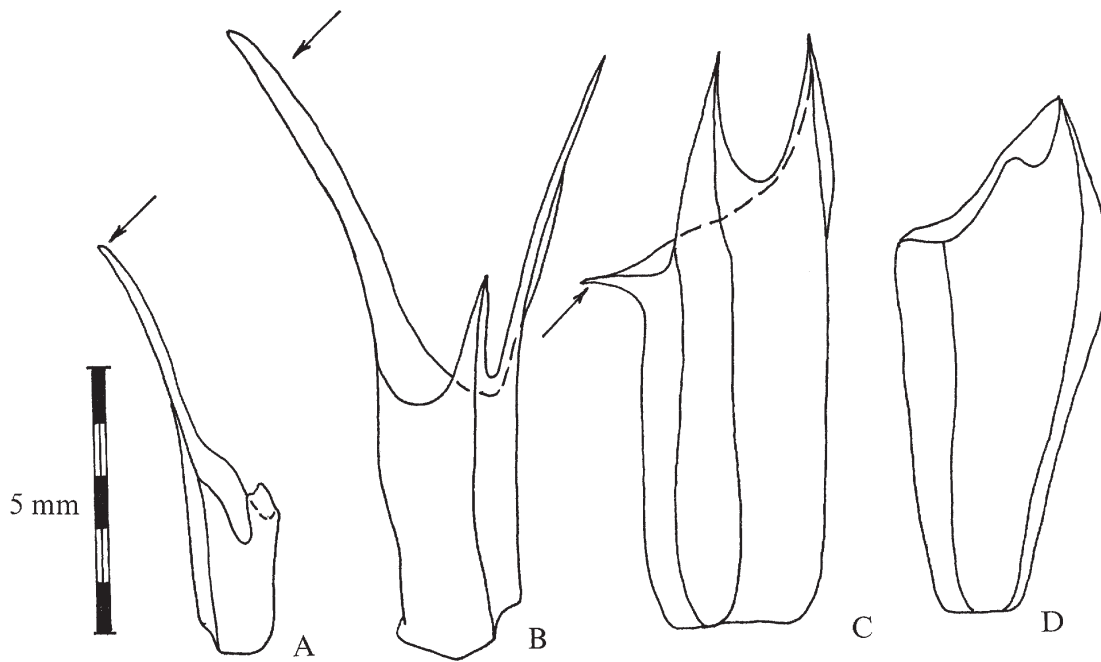

Figure 6 - Shape polymorphism of the basal involucre in *Involucrati*. A,B - *Crocus tommasinianus*. C,D - *C. vernus*. Arrows point the teeth, homologous to the foliage leaf lamina.

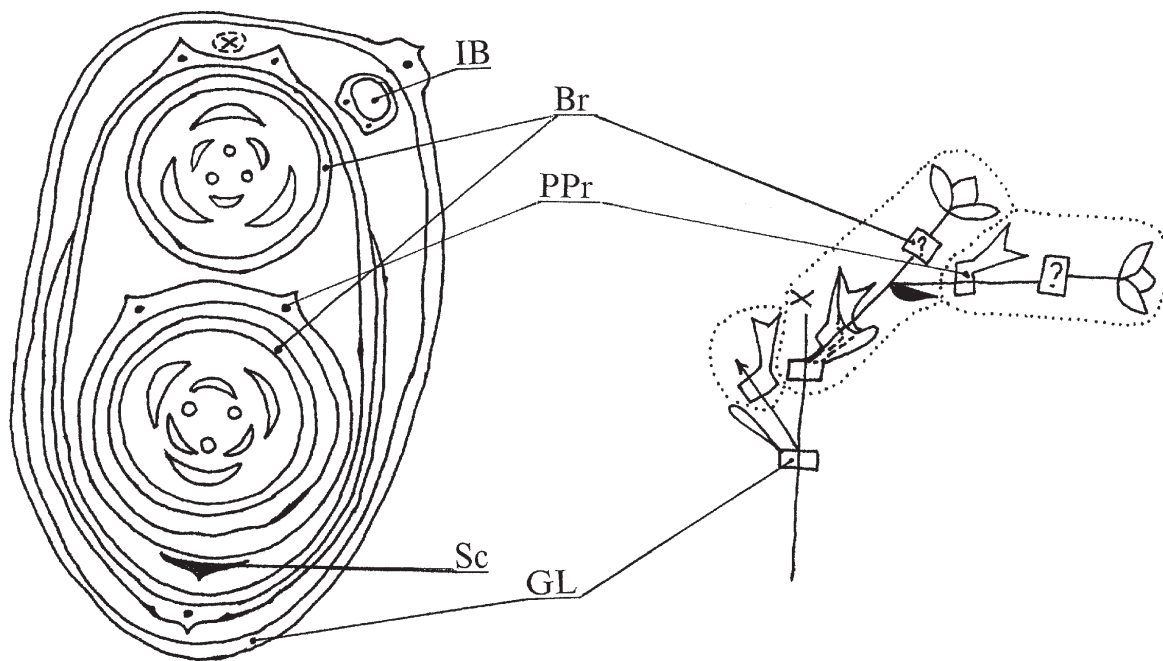

Figure 7 - Diagram of inflorescence in *Crocus vernus* (*Involucrati*) and its formal interpretation. Br - bract; GL - foliage leaf; IB - innovation bud; PPr - prophyll of paracladium; Sc - a small scale, bearing the paracladium in its axil.

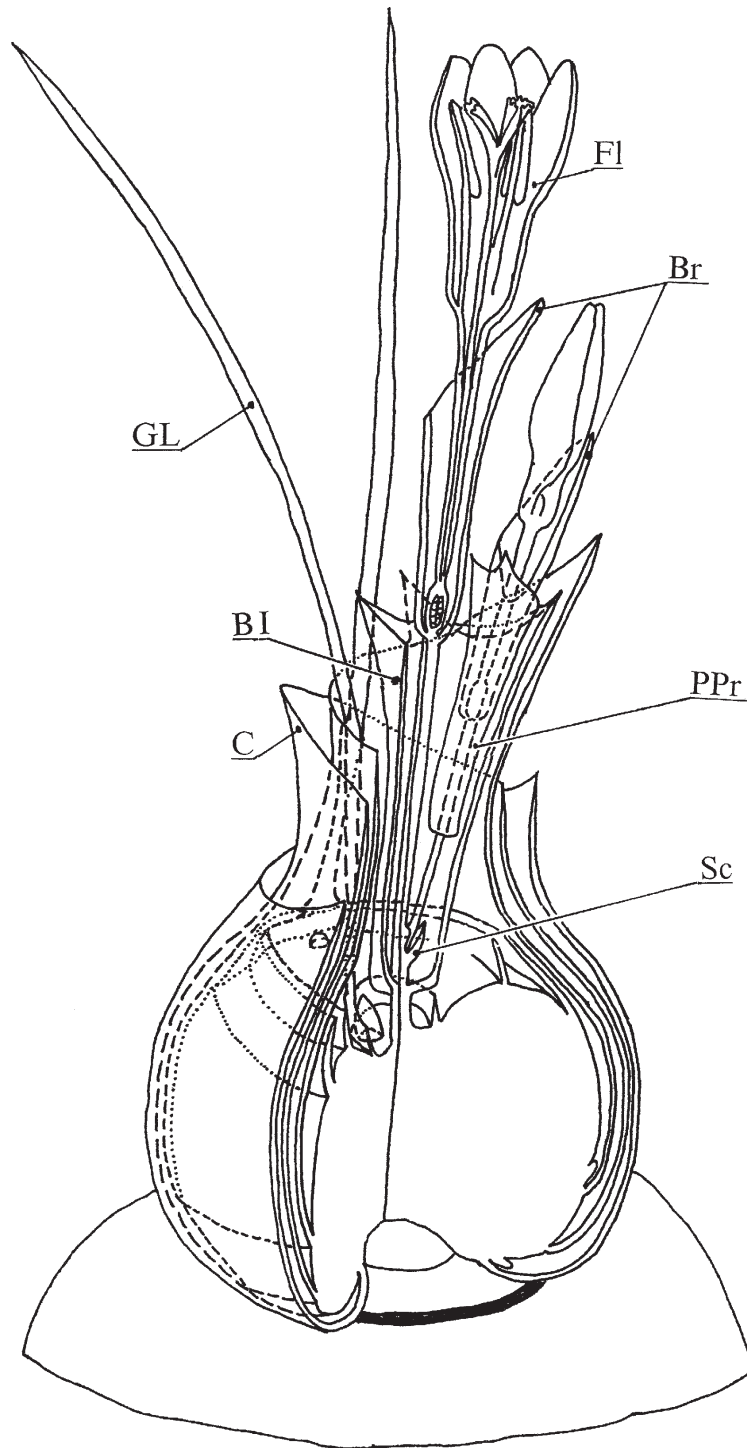

Figure 8 - Complete organ map of *Crocus vernus* (*Involucrati*). The structure of the bracts is disturbed by the flowers. Br - bract; C - cataphyll; GL - foliage leaf; Fl - flower; PPr - prophyll of paracladium; Sc - a small scale, bearing the paracladium in its axil; BI - basal involucre.

by the 2nd order axis. Its prophyll is fused with the uppermost leaf. In addition to a prophyll, the lateral (2nd) axis initiates a small scale (aborted or ablasted) with the paracladium in its axil. The apical region of the lateral axis is obscure because of the uncertain position and shape of the bract. The single paracladium bears a well-developed prophyll at the base. The apical region is obscure.

TWO PATTERNS OF INFLORESCENCE ARCHITECTURE IN *CROCUS*

In previous works, inflorescence characters were used to define two subgenera of *Crocus*. One of the main goals of our investigation was to demonstrate a correlation between these characters and the plant structure. It appears that the structure of the paracladial zone makes the difference between these two major groups of species even more acute (Table 1).

HOMOLOGY OF THE *CROCUS* INFLORESCENCE WITH THAT OF OTHER *IRIDACEAE*

Inflorescence terminology in *Iridaceae* may lead to confusion, mainly because the terms ‘bract’ and ‘bracteole’ appear to be non-homologous in different taxa. Our data reveal that in *C. flavus* the flower is surrounded by 2 or 3 prophylls of different shape and size, called ‘bract’ and ‘bracteole’. I distinguish these prophylls as follows: (1) A well-developed organ fused with the foliage leaf in the main inflorescence of *Involucrati* (e.g., *C. vernus*); (2) A scale (reduced leaf) in paracladia of *Nudiflori* (*C. flavus*); (3) A bract in *Nudiflori* (*C. flavus*); (4) A bracteole in *Nudiflori* (*C. flavus*); (5) A first leaf of the innovation bud.

Comparison of the bract and bracteole in *Crocus* with other genera of *Iridaceae* is problematical, because the inflorescence structure is currently insufficiently well-investigated. *Gladiolus* may be referred to as the ‘basic’ condition of inflorescence morphology in *Iridaceae* because it has all the typical organs: bracts on the main axis and bracteoles on the flower-bearing axis. Every member of *Iridaceae* would find homologous organs in the

TABLE 1 - DIFFERENCES BETWEEN *NUDIFLORI* AND *INVOLUCRATI*

Species analysed	Basal spathes (complex involucre)	Bracteole	Paracladia initiation	Position of paracladia	Position of innovation bud
i <i>C. flavus</i> , <i>C. chrysanthus</i> , <i>C. ancyrensis</i> , <i>C. tauricus</i> , <i>C. speciosus</i> , <i>C. sieberi</i> , <i>C. angustifolius</i>	absent	present	under environmental control	axils of foliage leaves	Variable, depends on paracladia development
ii <i>C. vernus</i> , <i>C. tommasinianus</i>	present	absent	obligate, 1 only	axil of scale inside involucre	conservative

Gladiolus inflorescence. *Crocus* bracts have the same position as the bracteole in *Gladiolus*, but the positions of the flower do not coincide. Homology of the *Crocus* bract with the prophyll of the paracladium in *Gladiolus* or *Freesia* would give better results. In the latter two genera bracts are homologous to phantoms in *Crocus*, but not to the *Crocus* bract.

In *Iris reticulata* there are no inflorescence organs homologous to those of *Crocus*. All the 'leaves' surrounding flower in *I. reticulata* M. Bieb. belong to the main axis, whereas in *Crocus* all the bracts and bracteoles are arranged on the 2nd or 3rd order axis. In *I. pallida* Lam., *I. albertii* Reg., *I. germanica* L., garden hybrids of bearded *Iris*, and *Tigridia pavonia* (L.P.) DC, prophylls of the lateral flowers are reduced. The only well-developed prophyll occurs at the base of paracladia in *Iris* inflorescences. The bract in *Crocus* finds no homologous organ in the spikes of these species. In *I. pseudacorus* L., *I. xiphium* L. and *I. foetidissima* L. the terminal flower unit contains one to several reduced flowers, which have their prophylls. These prophylls are homologous to the bract and (probably) bracteole in *Crocus*.

Thus the use of the same terminology for the organs, which fail the position criterion of homology, requires permanent specification of the taxon (*Crocus*, *Gladiolus* etc). Further development of homologous terminology in *Iridaceae* is desirable.

A LOOK TO THE FUTURE

In spite of this work, we still have no information about the structure of the apical region in some species of *Crocus*, and cannot establish the homologies of their bracts with organs of other species. To elucidate this problem it is necessary to do a developmental study of closely related *Crocus* species.

Another problem to be solved in the future is the evolutionary relationship between the two subgenera *Involucrati* and *Nudiflori*. The "bridge" between these two groups of species may be found in species with all three types of organ present (i.e. prophyll, bract and bracteole).

At the moment we have poor knowledge about the inflorescence in *Iridaceae*. The structure of *Gladiolus* spike is more or less clear. In *Iris* there is a remarkable polymorphism from one-flowered to well-branched inflorescences with well-developed or reduced prophylls, with a stable two-bract floral unit or a highly variable number of flowers. Until now, the use of inflorescence characters in systematics is very restricted, as we do not have complete information on inflorescence architecture, and methods of investigation are not sufficiently well developed.

CONCLUSIONS

1. The unequal length of the stamens in *Crocus* is a latent zygomorphy, indicated on lateral flowers.
2. The bract and bracteole in *C. flavus* are prophylls. The flower is on the 3rd (4th) order axis.
3. All *Crocus* species have prophylls at the bases of paracladia.
4. The basal spathe in *C. vernus* is a complex involucre, composed of a fused foliage leaf and prophyll.

5. *C. vernus* has a single paracladium, which is an obligate organ, initiated inside the involucre in the axil of a reduced leaf (scale).
6. Organ reduction occurs by three processes: (a) abortion, (b) ablasty and (c) fusion.

ACKNOWLEDGEMENTS

The author is very grateful to Dr. E.V. Klyujkov for the possibility of working with flowering plants from his collection, to Dr. O.V. Mitrofanova for kindly sending Crimean wild species, and to Dr. T. Stutzel and Dr. N.I. Shorina for discussion of results.

REFERENCES

- CHOOB V.V., 1995 - In vitro morphogenesis in different species of *Crocus* L. PhD dissertation, the Lomonosov Moscow State University, Moscow - in Russian.
- CHOOB V.V., 1999 - *Phantom leaves: a new look to the old problem of branching in Galanthus* (Amaryllidaceae). Syst. Geogr. Pl. **68**: 67-72. Proc. Of the 13th Symposium Morphology, Anatomy, and Systematics (Leuven, 1997).
- CHOOB V.V. AND KUSNETSOVA T.V., 1999 - *A critical revision of inflorescence structure in Crocus L. from subgenus Nudiflori Maw* (Iridaceae). Flora, 194: 229-235.
- EICHLER A.W., 1875 - *Blutendiagramme*. W. Engelmann, Leipzig- in German
- FEDCHENKO A., 1935 - *Crocus* L. In: Flora USSR IV. Academy of Science of USSR, Leningrad (in Russian).
- GOEBEL K., 1931 - *Blutenbildung und Sprossgestaltung (Anthokladien und Infloreszenzen)*. G. Fischer, Jena.
- KAPINOS G.E., 1965 - Biological characteristics of bulb and corm plant development in *Aspheron*. Academy of Science of Az.SSR, Baku (in Russian).
- MATHEW B.F., 1980 - *Crocus* L. In: Flora Europaea. Cambridge University, Cambridge **5**: 93-99.
- MAW G., 1886 - *A Monograph of the genus Crocus*. London.
- PAX F., 1889 - *Iridaceae*. In: *Die naturlischen Pflanzenfamilien* **11**(5): 137-157. Eds. Engler A. & Prantl K. Verl. W.Engelman, Leipzig.
- SCHUMANN K., 1894 - *Spross- und Blütenentwicklung in der Gattung Crocus nebst einigen Bemerkungen über die Gipfelblüte*. Botanische Zeitung **1**: 29-54.