

## Organism, Machine, Process.

### Towards a Process Ontology for Organismic Dynamics

Spyridon A. Koutroufinis<sup>a</sup>

<sup>a</sup> Technical University of Berlin - Institute for Philosophy  
Kypriou Agoniston, Greece

Corresponding author: Spyridon A. Koutroufinis [kout1967@mailbox.tu-berlin.de](mailto:kout1967@mailbox.tu-berlin.de)

#### Abstract

The creation of a process ontology for biology is one of the most ambitious and important projects of current philosophy of biology. Process ontology is usually seen as opposing mechanistic ontology which currently dominates biology. However, the terms 'process' and 'mechanistic' are not always clearly defined in current debates. In this paper I provide a new definition of 'mechanism' and 'mechanistic ontology' based on the most abstract definition of 'machine' – von Foerster's 'non-trivial machine' that is related to Turing machine. I argue that the main methods of modeling used in systems biology rest upon the implicit assumption that organisms abide by the non-trivial or Turing machine logic. By showing that organisms and machines obey two incompatible logics of causality I demonstrate the limits of this assumption. The paper concludes by introducing an organism-centered concept of process and arguing that Whitehead's process metaphysics offers a way of understanding organisms as exemplifications of a specific category of process.

**Keywords:** organism, machine, process ontology, mechanism, Turing-machine, causality

**Citation:** Koutroufinis, SA., 2017, "Organism, Machine, Process. Towards a Process Ontology for Organismic Dynamics", *Organisms. Journal of Biological Sciences*, vol. 1, no. 1, pp. 23 - 44. DOI: 10.13133/2532-5876\_1.8.

## 1. Introduction: the main ontologies of western intellectual tradition in biology

Every scientific theory is based on a specific ontology. Each is explicitly or at least implicitly underlain by a priori metaphysical assumptions about the entities, their essential properties, and their relations that generate the natural phenomena under consideration. Those assumptions are the most fundamental propositions that many if not all natural sciences share. They are defended against all attempts to revise them and can therefore survive even the introduction of radical new ideas and theories such as the second law of thermodynamics, the evolution of the species, and the theory of relativity. The history of western sciences and philosophy can be considered as an adventure of ideas borne by three main ontologies succeeding one another.

The transition from the metaphysical pluralism of competing Presocratic schools to classic Greek philosophy in Athens of the 4th century B.C. is due to the emergence of the concept of *substance* (οὐσία, *ousia*) as introduced by Plato and refined by Aristotle. In his early work *Categories* Aristotle made the seminal distinction between two kinds of substance. As 'first substance' he described each individual actual being such as a particular human or tree. Under 'second substance' he understood a universal abstract entity, such as 'oak' or 'redwood,' which is predicable of a first substance.<sup>1</sup> It is the essence, i.e., the reason of all its essential features, which must be attributed to an individual being in order to characterize it. In Aristotle's *Categories* the term 'second substance' is used in the same sense as

<sup>1</sup> When saying "this tree is a redwood" we ascribe second substance, i.e., the species redwood, to a first substance, i.e., a particular tree ("this tree").

the term *eidōs* (εἶδος) is used in *Physics* and *Metaphysics*. In these later writings *eidōs* has the meaning of ‘species’ or ‘form.’ A particular *eidōs* specifies many particular first substances (Aristotle 2006, 1037a 29-30). In these works the term ‘form’ (*eidōs*) means the essence of actual beings and not just their external shape which Aristotle called ‘morphé’ (μορφή).<sup>2</sup> In the case of organisms *eidōs* refers to the biological species to which they belong (Aristotle 2008, 198a 20-198 b3). Under the influence of Aristotelian substance ontology *eidōs* became the main principle of reasoning about nature. It was considered to be the active principle that forms matter, the latter being understood as a pure potential, i.e., an entirely passive principle. Thus in Aristotle’s theory of causality *eidōs* is conceived of as a cause, the so-called ‘formal cause.’ It always acts on matter to some end, called ‘final cause’ or ‘telos’ (τέλος). The central role of form (*eidōs*) in explaining organism formation and persistence makes it the primary common element in the biological thought of ancient, medieval, and early modern times.

The decline of this ontology begins with the scientific revolution initiated by the introduction of the Copernican heliocentric system in the renaissance. In the 17<sup>th</sup> century philosophers and physicists replaced final and formal cause with blind<sup>3</sup> mechanical contact-forces (Bacon, Galileo, Hobbes, Descartes) or, equally blind, action-at-a-distance-forces (Newton). Their ontology can be labeled as ‘mechanistic systems ontology’ or just ‘mechanistic ontology.’ For principal reasons, since its very origin, this ontology considers Aristotelian final and formal cause (*eidōs*) as being entirely superfluous. Mechanistic ontology totally reverses the main principle of Aristotelian philosophy of nature by reducing essential features of any actual being to its material elements and their interactions. Mechanistic systems ontology is not free from overlapping with substance ontology. It rather emerged after the ancient and medieval concept of substance was essentially transformed. Descartes’ radical reformulation of the concept of substance through his extremely influential distinction between extended and non-extended substances divided Aristotle’s first substances into two ontologically different groups, bodies and minds. This is clearly a non-Aristotelian way of thinking. More importantly, both kinds of Cartesian substance were conceived of as something that “exists in such a way that it does not depend

on anything else for its existence”, i.e., as a self-sufficient being (Descartes 1984, §51). As such it requires no relation to anything else in order to exist, which is clearly orthogonal to Aristotle’s substance ontology.<sup>4</sup>

In the 17<sup>th</sup> century Newton succeeded in describing the dynamics of the solar system without any reference to any kind of formal or final cause. Newtonian mechanics provided an example of mechanistic systems ontology par excellence. In the mid of 18<sup>th</sup> century, based on Newtonian mechanics, Kant showed that, contrary to Newton’s suspicion, even the explanation of the solar system’s generation could be explained without recourse to any non-mechanical cause. Another important milestone in the deconstruction of substance ontology came with the historization of the species concept in Darwinism. Since its emergence, evolution theory has been mainly interpreted as a denial of the constancy of biological taxonomic forms, and thereby a radical refutation of Aristotelian form (*eidōs*).

Most contemporary biologists and philosophers of biology accept some version of materialism stemming from this mechanistic ontology. Its triumph in biological thought began with Descartes’ attempt to explain the formation of the embryo and the sustainment of an organism in terms of mechanical contact forces between elementary extended substances, i.e., bits of matter, in his work *Description du corps humaine* (1996, 252-255). In the mid of the 19<sup>th</sup> century, the Germans Carl Ludwig, Hermann von Helmholtz, and Emil du Bois-Reymond tried to base physiology on Descartes’ methodology, assuming that the function of a whole organism can be explained by summing the results obtained from the analysis of the properties of isolated organs (Rothschuh 1968, 259). In 1865 French physiologist Claude Bernard created a considerably more synthetic view. He introduced the earliest version of ‘organicism,’ according which living beings consist of diverse material processes that determine each other synergistically (Ibid. 272). Due to his emphasis on synergism Bernard may be considered the first non Cartesian materialistic physiologist. In the early 20<sup>th</sup> century, with the advent of theoretical biology as an initially neo-vitalistically oriented discipline, substance ontology experienced a renaissance in organism theory. This ended, however, with the establishment of mathematical theoretical biology early in the 1930’s—preceded in the late 1920’s by the first quantitative systems theoretical formalisms

<sup>2</sup> Aristotle sometimes uses the term ‘morphé’ as meaning both external shape and essence.

<sup>3</sup> In this context ‘blind’ means devoid of any determination with respect to consequences or sensitivity to the larger context.

<sup>4</sup> Aristotle thought of the cosmos as an eternal organism that was organized according divine logic. Therefore all first and second substances are internally related to each other as are the parts of an organism.

describing electrical networks (Janich and Weingarten 1999, 90)—and especially with the rise of molecular biology twenty five years later. In the 1990's, due to the emergence of synthetic and systems biology (see below), biological reasoning became even more systemic. Currently, Aristotle's ontology, especially his concept of form (eidos), has been effectively banned from biology and the philosophy of biology (Griffiths 2002, 72; Sober 1980, 249). Nevertheless, in the last decades seminal philosophers have revived a kind of biological essentialism, though one that should not be seen as a renaissance of Aristotelian 'second substance' or form of any other kind of substantialism (Kripke 1980; Putnam 1975; Wiggins 1980). Recently Devitt has defended the "idea that biological natural kinds, particularly a species such as dogs, have intrinsic underlying natures" (2010, 648), however without committing himself to Aristotelian essentialism (Ibid. 651).

Currently, a new ontology that explicitly refutes all versions of both mechanistic and substantialist thought is being introduced in the philosophy of biology. For example, Baptiste and Dupré argue in the favor of a network logic that abandons species centered explanations (2013, 386) and sees stable biological units, such as organisms, cells, and genes, as entities "stabilized either by a single type of process, or by multiple types of processes" (Ibid. 396, see also: Dupré 2012, 70f). Similar positions are championed in evolutionary developmental biology (Oyama et al. 2001). The biologist Gernot Falkner, the biological anthropologist Terrence W. Deacon and I have also introduced non-mechanistic ways of thinking about organisms as processes (Deacon 2012; Falkner and Falkner 2014; Koutroufinis 2014a,b, 2013, 2009; Koutroufinis and Wessel 2011).<sup>5</sup> It is too early, however, to judge whether a paradigm shift in biological reasoning lies ahead. It is certain, nevertheless, that many process-centered approaches in current biological thought are inspired by a third major type of ontology found in western thought, which is labeled *process ontology*. It emerged in the early 20<sup>th</sup> century in the writings of Alfred North Whitehead but was clearly anticipated in the works of William James, Henri Bergson,<sup>6</sup> and Charles Sanders Peirce.

<sup>5</sup> Falkner anchors his perspective of organism on Whitehead's metaphysics. Deacon represents an emergentistic process-oriented theory about the origins of life and semiosis. He is sympathetic to Whitehead's ontology but rejects one of its essential features: pan-experientialism. I focus on principal limitations of organism theories based on dynamical systems theories and suggest different ways of going beyond them.

<sup>6</sup> Bergson is often considered to be a vitalist. This is a misinterpretation, since vitalism, in the strict sense of this term,

This essay is based on two main convictions: first, that a process ontology for biology requires above all a process-centered understanding of the concept of organism and, second, that this can be achieved only on the basis of a philosophically elaborate concept of 'process' that considerably differs from naïve meaning of this word in both scientific and everyday language. These are absent in today's systems biology and theoretical approaches to life in general. This paper is an attempt to change this situation. In section 2, I suggest a way to distinct systems biology from theoretical biology. In section 3, I point out the principal limitations of contemporary systems biology. In section 4, I provide a definition of the terms 'mechanism' and 'mechanistic ontology' using von Foerster's concept of *non-trivial machine* that he has introduced as synonym of *Turing machine*. Then I show that on the one hand, the modeling and mathematical formalisms used in systems biology, all contemporary machines, and dynamic systems theory, and on the other hand, organisms result from two radically different logics of causal organization. In section 5, I suggest a metaphysically neutral concept of process based on the logic of organismic causality. Whitehead's metaphysics is introduced as a possible way to apply this concept of process to organisms. Finally, in section 6 (conclusion), I suggest the introduction of a new theoretical biology on the basis of process ontology.

## 2. Theoretical biology and systems biology: Models explaining causality and models describing behavior

Theoretical biology began in the early 20<sup>th</sup> century with the works of German (or German speaking) biologists, such as the vitalist Johannes Reinke, the Kantian Jakob von Uexküll and the materialist Julius Schaxel. Its aim was to develop a philosophically consistent foundation for biology. In its beginnings theoretical biology was what philosophy of biology is today. In the 1920s, Alfred Lotka and Vito Volterra developed mathematical models of population dynamics. These approaches became the forerunners of the systematic mathematization of theoretical biology, such as developed in the works of Ludwig von Bertalanffy, Nicolas Rashevsky, Erwin Schrödinger, and Alan Turing.

---

presupposes some kind of substance ontology. In his major works on philosophy of nature and mind, *Creative Evolution*, *Matter and Memory*, and *Time and Free Will* Bergson takes a decisive process philosophical perspective and reformulates central metaphysical issues in opposition to substance ontology.

With the development of theories of non-linear dynamic systems and the derivative concepts of self-organization, chaos and complexity with works of William Ashby, Heinz von Foerster, Ilya Prigogine, Hermann Haken, and Stuart Kauffman theoretical biology became a mathematical discipline—which is why it is often referred to as ‘biomathematics’ (Kauffman 1995, 1993; Murray 1993; Goodwin 1994; Goldbeter 1997; Noble 2006). As a result, the originally wide range of topics became much more limited. Today theoretical biology has largely been reduced to mathematical modeling and computer simulations of biological processes.

In the 1990s another biological discipline emerged—systems biology. Since it supports a change of attention from molecular detail to systems theoretical consideration of organismic processes, it is in an important respect antagonistic to molecular biology. The central task of systems biology is the study of complex cellular processes. Since a main aim of this discipline is to contribute to improving understanding and medical treatment of diseases like cancer and Parkinson, there is a narrow connection of systems biology to the medical-pharmaceutical research and industry.

Most models used in empirical biosciences are models for describing the behavior of systems. The criterion of their value is whether they facilitate the further research by enabling predictions and formulating new hypotheses. In mathematical theoretical biology, as it was introduced by Lotka, Volterra, von Bertalanffy, and Turing, first one had to have a certain hypothesis about a causal mechanism which, in the second step, would be translated into a mathematical formalism. In carrying this out, a single method was applied: biological systems were considered as dynamical systems. As such they could be represented by systems of coupled differential equations and solved under certain parameter values that had to be given. In contrast, in systems biology a variety of different methods may be applied at the same time if this helps outlining a causal mechanism, the corresponding formalism, and the parameters that allow making the desired predictions (MacLeod and Nersessian 2013). *Utility rather than theoretical stringency is the criterion for assessing theoretical adequacy in systems biology.* Thus it should be seen as being closer to engineering than to science. It is not surprising that many systems biologists do not consider their discipline to be theoretical biology (Laubichler 2005, 111).

Another way to consider the essential difference between theoretical and systems biology in respect to the theory of organism is to make a clear discrimination between two kinds of models (Gutmann 1995, 19f.;

Janich and Weingarten 1999, 86ff.). First, there are models for explaining *how* the behavior of a system is generated. Those models are developed for *explaining the internal causality* of a system. Newton’s model of the solar system, for example, qualifies as a model that aims at explaining the causal relations between celestial bodies. Second, there are models that aim at *describing* the known behavior of a system, so that predictions of new behaviors emerging under new conditions can be made. The ancient astronomy that was based on the mathematics of epicycles provided a model describing the behavior of the solar system without explaining the underlying causality (gravitational attraction). Systems biology may content itself with making models that predict the behavior of biological systems in a way that supports the development of new biomedical applications. In contrast, the role of theoretical biology should be to suggest models that *explain the causality* of organisms. The easiest way to proceed to this difficult enterprise is showing first a principal theoretical reason why systems biological models should be considered as models for predicting the behavior and not as models for explaining the causality of organisms.

### 3. On principal limitations of formal models of organismic dynamics

Aided by the theory of dynamic systems, the modern paradigm of self-organization has become a main pillar of mathematical theoretical biology and systems biology as well. A system is defined as a *dynamic system* if its state at any given moment can be described as a limited set of time-dependent, or state variables  $x(t) = x_1(t), x_2(t), \dots, x_n(t)$ , for which a function  $F$  can be formulated by stating mathematically the connection between states at times  $t$  and  $t + \delta t$ , where  $\delta t$  is a time step that may be infinitesimally small. The properties of this function are presumed to reflect the causal relationships at work within the system. The set of state variables  $[x_1(t), x_2(t), \dots, x_n(t)]$  defines an abstract space, the system’s so-called ‘state-space.’ Usually, every state  $x(t)$  in a stable dynamical system can be calculated from its preceding state  $x(t - \delta t)$ .<sup>7</sup> It is important to keep in mind that the development of a dynamic system is not merely the result of time-dependent variables  $x(t)$ , but depends

<sup>7</sup> This is sometimes not possible in unstable systems because some states have more than one possible successor state under actual (natural) conditions. But even these systems allow, at least in principle, the calculation of all *potential* future states of the system’s development given its state at a certain time.

also on a group of quantities the value of which cannot be varied by the system's dynamics. The most abstract formula for a dynamic system must therefore be:

$$x(t + \delta t) = F[x(t), q, p, \delta t]; p = p_1, p_2, \dots, p_m$$

(Formula 1)

This formula is a slight variation of a formula provided by the theorists of self-organization Werner Ebeling and Igor Sokolov (2005, 40). The letter  $q$  represents a set of so called 'independent variables.' They are the initial and boundary conditions of the system, i.e., quantities that are externally imposed on the dynamic system. Boundary conditions include the material and energetic gradients that remove dynamic systems from the state of thermodynamic equilibrium. They determine the system's energetic and material openness. The letter  $p$  represents a set of parameters. Some parameters represent the degree of activity of specific molecules in systems-biological simulations, while others represent the rate coefficient of reactions in chemical kinetics. Some other parameters are abstract relationships, summarizing the causal relations between variables of the cell such as volume, temperature, pressure, pH-value, etc. Parameters are either constants or entail many constants the value of which cannot be varied by the system's dynamics. In biological modeling, parameters are either experimentally derived or estimated or simply taken from the literature (Voit 2000, 146-173). In most cases all independent variables and parameters are preset by the experimenters or model makers and are held constant in experiments and corresponding computer simulations. In other words, *they are externally fixed factors that cannot be varied by the system's own dynamics.* The reason for this is that those quantities canalize the development of the state variables  $x(t)$  in the state-space so that they are logical presuppositions of the systems possible dynamics.

### 3.1. Examples of formal models in systems-biology

Systems biologists can employ a variety of different methods depending on the problem to be solved (MacLeod and Nersessian 2013, 536). Systems biologists who model processes as systems of differential equations often focus on the modeling of the dynamics of genetic, metabolic and signal pathways (Downward 2001; Elowitz and Leibler 2000; Ferrel and Xiong 2001; Gardner et al. 2000; Meinhardt and Gierer 2000; Murray 1993; Tyson et al. 2003; Van Hoek 2008). They also study the behavior of larger network systems constituted by coupling these

pathways, such as might occur in embryogenesis (Collier et al. 1996; Goldbeter 1997; Goodwin 1994; Guidicelli and Lewis 2004; Karr et al. 2012; Meinhardt 2003; Meinhardt and Gierer 2000; Murray 1993; Nijhout 2003; Panning et al. 2007; Turing 1952). From the perspective of the theory of dynamic systems, the final-state-directedness of embryogenesis, cell cycles, and other final-state-directed phenomena is thereby reduced to the dynamics of an enormously complex system of positively and negatively coupled biomolecular reactions.

In order to demonstrate how this approach works, I will introduce an exemplary case of the mathematical analysis of a biological system implemented with ordinary differential equations. Based on the Operon-model of Jakob and Monod, Gardner et al. presented a model for the mutual regulation of the activity of two genes. This model is often considered as a milestone of synthetic biology.<sup>8</sup> Both genes transcribe a so-called repressor protein which blocks the activity of the other gene, so that both genes inhibit each other. The dynamics of this system consists of two interwoven negative feedback relationships that can be described by two state variables,  $U$  and  $V$ , which are associated with the concentrations of each repressor protein, respectively. The variation of the concentrations of both proteins can be represented by two coupled differential equations (Gardner et al. 2000, 339).

$$\frac{dU}{d\tau} = \frac{\alpha_1}{1+V^\beta} - U$$

(Formula 2)

$$\frac{dV}{d\tau} = \frac{\alpha_2}{1+U^\gamma} - V$$

(Formula 3)

These coupled non-linear equations are so-called 'dimensionless' equations.<sup>9</sup> The quantities  $\alpha_1$ ,  $\alpha_2$ ,  $\beta$ , and  $\gamma$  are the parameters. Their value is determined by the experimenters. Certain combinations of the four parameters lead to a bistable behavior, meaning that two stable alternative terminal states—in the language of dynamical systems theory: two attractors—are possible.

<sup>8</sup> This is asserted in the editorial article of *Nature* "Ten years of synergy" that was published in 2010.

<sup>9</sup> In dimensionless equations the quantities have to be recast by judicious scaling so that no units need appear. In the two equations provided by Gardner et al. the left sides seem to have the quality of rate and the right sides the quality of concentration. However  $U$  and  $V$  do not represent concentrations and  $\tau$  does not represent time. The two sides of the equations can be reconciled because these symbols represent only values associated with concentrations or time.

Bistable systems are common in theoretical and systems biology, since organisms take advantage of bistability because it increases their flexibility and thus their adaptability.

A few years ago van Hoek suggested a metabolic pathway model for the behavior of *Escherichia coli*. Following the same methodology as that of the authors introduced above, he employed ten coupled ordinary differential equations for the solution of which he used 58 parameters (2008, 18-20, 45-47).

In the last decade several research groups performed computer simulations of whole cells. A model of the cell cycle of yeast operating with ordinary differential equations was published a few years ago by Panning et al. (2007). In this model the yeast cell is reduced to 36 state variables. For their computation the model makers use 143 parameters. So, on average for the computation of one variable they use 4 parameters. In 2012 a group of bioengineers from Stanford University published a whole-cell computational model of the bacterium *Mycoplasma genitalium* that “includes all of its molecular components and their interactions” (Karr et al. 2012, 389). The life cycle of the bacterium is represented by 16 state variables such as copy numbers of metabolites, RNA, and proteins, metabolic reaction fluxes, mass, volume, and shape of the cell (Ibid. 390). For the computation of those variables the model makers use “more than 1,900 experimentally observed parameters” (Ibid. 391). Most of them “were implemented as originally reported” in “over 900 publications” and “several other parameters were carefully reconciled” by the model makers themselves in order to make the results computed by the model agree with experimentally derived data (Ibid.). Next, the model was validated against a large number of independent data sets, i.e. those that had not been used in the construction of the model (Ibid.).

Biochemical systems theory (BST) is a mathematical and computational framework based on ordinary differential equations. Initially introduced by Savageau in the 1960's for the study of biochemical systems it has developed to a method for analyzing and simulating different kinds of biological processes, such as metabolic control, gene expression and signaling (Voit 2013). The starting hypothesis of BST is that in a biochemical system consisting of  $n$  substances the rate of change of the concentration of a substance  $x_i$ , a dependent variable, can be represented by the following equation:

$$dx_i/dt = V_i^+(x_1, x_2, \dots, x_n) - V_i^-(x_1, x_2, \dots, x_n)$$

(Formula 4)

where  $V_i^+$  and  $V_i^-$  are the production and depletion functions of  $x_i$  depending on the system's state, i.e., to the concentrations  $x_1, x_2, \dots, x_n$  of the other substances (Voit 2000, 47). In realistic situations these functions are usually not known and can be not determined experimentally. According Taylor's theorem, however, at a specific point  $x = b$  any infinitely differentiable function  $f(x)$  can be reduced to a sum of terms that are calculated from the values of the function's derivatives. This and basic features of the logarithmic function make possible equating both unknown and probably very complicated functions with products of rate constants and power functions “of exactly those variables on which the production and degradation depend” (Ibid. 70):

$$\text{(Formula 5)} \quad V_i^+ = \alpha_i \Pi(x_j)^{g_{ij}}, \quad V_i^- = \beta_i \Pi(x_j)^{h_{ij}}$$

(with  $j = 1 \dots n$ )

In this formula  $\alpha_i$ ,  $\beta_i$ ,  $g_{ij}$ , and  $h_{ij}$  are independent variables and parameters (ibid 51f.). This formula, however, is valid only in the proximity of a so called ‘operating point’ which is typically the system's steady state (Ibid. 83; Savageau 2009, 6436; Voit 2013, 4, 6, 23). In the proximity of steady states non-linearities of metabolic, genetic and signal processes are represented by linear equations which are much easier to handle (Savageau 1988; Voit 2013, 23; Voit and Schubauer-Berigan 1998). This is the essential benefit of BST, although concentrations of biomolecules are validly represented only in a limited area around the operating point (Ibid.).

Besides systems of ordinary or partial differential equations theoretical and systems biologists also employ cellular automata and so called agent-based modeling. The theory of cellular automata, as it has been introduced by John von Neumann in the early 1950's, is the basis of “the simplest mathematical representation of a much broader class of complex systems” (Ilachinski 2001, 1). A cellular automaton consists of a one-, two-, or multi-dimensional lattice of equivalent cells, each of which takes a finite number of discrete states at discrete time units. The state of a particular cell at time  $t + \Delta t$  is determined by a specific local transition rule which takes into account only the states of the cells located in its local neighborhood at time  $t$  (Ibid. 5). The state of a particular cell at position  $x$  at time  $t + \Delta t$  is given by the following formula:

$$s(x, t + \Delta t) = \Phi_x [c(x, t)]$$

(Formula 6)

In this formula  $c(x, t)$  is the configuration of the neighborhood of cell  $x$  and  $\Phi_x$  is the local rule that assigns states to cell  $x$  in dependence of the state of its neighborhood (Peak et al. 2004, 919).  $\Delta t$  represents the time step which, other than in continuous dynamic systems (see formula 1), cannot be infinitesimally small. The totality of the local rules  $\Phi_x$  defines a global transition rule  $\Phi$  that determines how the total state  $C$  of the entire automaton changes after a time step:

$$C(t + \Delta t) = \Phi[C(t)]$$

(Formula 7)

A main reason for the popularity of cellular automata among complex systems researchers is their capacity to generate extremely complicated behaviors producing long-range order despite obeying only simple local rules. Cellular automata have been applied to simulations of various biological phenomena such as the dynamics of stomatal apertures on plant leave (Peak 2004, 920ff.), the complex patterns on the surfaces of seashells (Baker and Herman 1972; Coombes 2009; Waddington and Cowe 1969; Wolfram 1984), and the waves of color running through the skin of mollusks (Packard 2001).

Agent-based modeling is a simulation method that has been developed on the basis of cellular automata (Emrich 2007, 18). It is often applied to studies of the behavior of complex systems consisting of a big number of organisms such as ecological systems and bacterial biofilms (Grimm et al. 2006, 2010). In two papers published a few years ago agent-based modeling has been used to simulate the growth of populations of individual microbes in biofilms immersed in aquatic environments (Lardon et al. 2011) and to simulate the dynamics of horizontal gene transfer between bacteria living in biofilms (Merkey et al. 2011). Grimm et al. have published a “proposed standard protocol” for describing agent-based modeling that may be used as general guide for this kind of simulations (2006, 2010). As with modeling using differential equations this method is also based on the presetting of a number of independent variables and parameters, usually taken from the literature (Lardon et al. 2011, 2427ff, 2433; van der Wal et al. 2013, 3, 9.) or assumed or acquired by measurements (Merkey et al. 2011, 2436, 2440 ff.). The number of these is typically significantly larger than the number of state variables used to compute the dynamics.

*All methods introduced above—solving of systems of non-linear equations, biochemical systems theory, cellular automata, and agent based modeling—share three essential features.*

First, they are methods for studying and manipulating the behavior of biological processes by treating them as self-organized dynamic systems. Thus they may be subsumed to the umbrella term ‘dynamic systems theories.’ Second, they do not explicitly address the distance between biological models and real biological processes and systems. Third, they operate based on the same implicit assumptions about the roles of different causal factors—dependent variables, independent variables, and parameters—in dynamics of biological systems. For the purpose of this essay, this is the most important feature of those methods. Therefore, it will be analyzed in the next section.

### 3.2. Strict separation of intrinsic from extrinsic causal factors in systems biology

The development of a dynamic system is displayed by trajectories in its state space. The essential feature of all kinds of self-organized systems, such as Bénard convection cells, chemical dissipative structures, and systems biological formal models, is that *their trajectories converge to small areas of their state-space* dependent on the initial conditions.

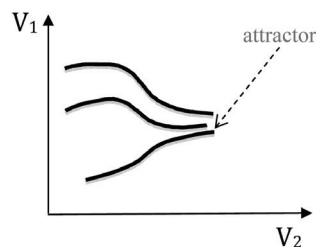

**Fig.1.** Convergence of trajectories in a two-dimensional state-space.

Emergence of self-organized dynamics means that the total number of the possible states of a system’s behavior is less than the sum of the numbers of the possible states of the behavior of its elements: self-organization is elimination of possibilities. This applies not only to systems studied by the theory of self-organization but also to all biological processes. Bio-molecular processes, cells, organisms, ecosystems, and the whole biosphere actualize only an extremely small number of the totality of possible states contained in their state-spaces. Thus *the study of biological processes and their models requires first an understanding of the causal factors that restrict their development to a small number of possible states.*

I use the term ‘causal factors’ to refer to all factors that contribute to the determination of a dynamic system’s

development which in state-spaces is represented by a trajectory, for example, energetic and material quantities and relations between such quantities. In what follows I will use the generic term 'factors' to refer to causal factors. In formal models used in both physics and systems biology there are two clearly distinct kinds of factors at work: intrinsic and extrinsic ones.

*Intrinsic factors* of formal models include those factors which are generated by the system's dynamics itself. They are the time dependent values of dependent or state variables. In formula 1  $x(t)$  and in formulas 2 and 3 the changing values of  $U$  and  $V$  are the only intrinsic factors. Intrinsic factors are also represented by  $x_i$  (formula 4),  $x_j$  (formula 5),  $s$  and  $c$  (formula 6), as well as  $C(t)$  and  $C(t+\Delta t)$  (formula 7). The trajectory which displays a system's dynamic behavior in the state space necessarily displays also the variation of its intrinsic factors, since each dimension of the state space represents a certain quantity being one of the system's state variables, i.e., one of its intrinsic factors.

*Extrinsic factors* of formal models include all the factors that contribute to the generation of intrinsic factors but are *not* influenced by any intrinsic dynamics, i.e., the respective state of the system. Independent variables and parameters are extrinsic factors. The quantities  $\alpha_1$ ,  $\alpha_2$ ,  $\beta$ , and  $\gamma$  (formulas 2 and 3) and  $\alpha_r$ ,  $\beta_r$ ,  $g_{ij}$ , and  $h_{ij}$  (formula 5) are extrinsic factors.

In this essay 'intrinsic' means 'dependent upon dynamics' and 'extrinsic' means 'independent of dynamics.'

In the formalisms of systems biology the most complex factors are described by the *differential equations* or *the systems of coupled differential equations* which determine the variation of the state variables of continuous dynamic systems and the *rules* which determine the variation of the state of cellular automata. Those systems of equations and rules are relations between the less complex intrinsic and extrinsic factors. In contemporary formalisms the formal structures are not influenced by the system's change of states. They are static which clearly qualifies them as extrinsic factors. As relations between simpler factors they can be characterized as *second-order extrinsic factors*. Analogously, dependent variables, independent variables, and parameters can be understood as *first-order factors*, either intrinsic or extrinsic ones. A system of coupled differential equations, such as the system consisting of formulas 2 and 3, is a single indivisible second-order extrinsic factor. Function  $F$  (formula 1), the system consisting of  $V_i^+$  and  $V_i^-$  (formula 5), and  $\Phi$  (formula 7) are other examples for second-order extrinsic factors. For principal reasons,

to be discussed below, in contemporary systems biology there are no second-order intrinsic factors.

There are two essential differences between first order intrinsic factors on the one hand and first- and second-order extrinsic factors on the other.

1. Whereas new values of the state variables are continuously generated, all extrinsic factors are usually held constant during an experiment or a computer simulation of a process. In other words, extrinsic factors are usually static.
2. All intrinsic factors are dynamically interconnected, i.e., they mutually determine each others' values. This explains why the behavior of a dynamic system's state variables is usually described by systems of coupled differential equations (see formulas 2 and 3). To a certain degree intrinsic factors obey a form of self-referential or cyclical causation. There is nothing like this in the relation of extrinsic factors to each other, since they do not depend on the system's dynamics and therefore can be externally regulated in total isolation from each other.

Because of the one-sided causal dependence of intrinsic on extrinsic factors there is a sharp logical distinction between both kinds of factors. One may also talk of a *logical dualism or dichotomy* between intrinsic and extrinsic factors. This not only applies to systems biological modeling; it is rather a fundamental feature of the theory of self-organization. The role that both essentially different kinds of factors play in the general logic of self-organization as well as in systems biology, which is a specific application of this logic, can be depicted as follows:

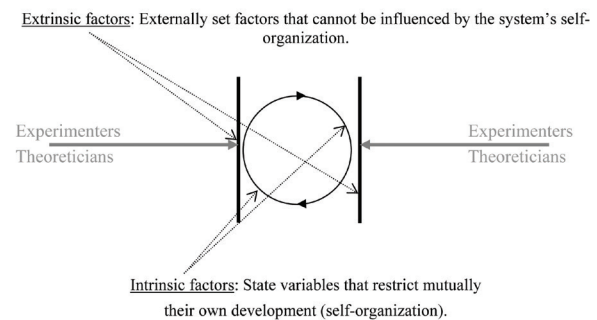

**Fig. 2.** The logic of theory of self-organization and system biology in respect of casual factors

If the imposition of extrinsic factors radically reduces the possible ways that the system's elements can interact with one another, the generated intrinsic



factors or state variables will exhibit a final-state-directed dynamic behavior. As they mutually force their values to converge towards an increasingly limited area of the state space an attractor emerges. First and second-order extrinsic factors play a crucial role in the end-directedness of a system's development since they decisively influence the pattern of the emerging attractor. Both attractors of the bistable genetic network described above emerge only for specific ratios between the first-order extrinsic factors (parameters)  $\alpha_1$ ,  $\alpha_2$ ,  $\beta$ , and  $\gamma$ , and the second-order extrinsic factors defined by both differential equations. It is noteworthy that the modeling of the self-organization of just two state or dependent variables, U and V, requires that four parameters be externally determined. This is not an exception but rather the normal case: *In systems biology models self-organized behavior appears only if the number of first-order extrinsic factors exceeds several times the number of the intrinsic ones.*

#### 4. Logic of organisms vs. logic of machines

'Mechanistic thought' is very widespread in contemporary biosciences. Unfortunately, despite the attempts of philosophers of science to define the terms 'mechanistic' and 'mechanism' (Bechtel 2007; Buzzoni 2016; Craver 2007, 2013; Glennan 2002; Machamer, Darden, Craver 2000; Nicholson 2012), it is not always clear what bioscientists mean by using those terms. In the following section these concepts are given an explicit interpretation and used to show in what sense systems biology is mechanistic.

##### 4.1. Logic of organisms

The distinction between intrinsic and extrinsic factors plays a critical role in systems biological formalisms, though it need not be restricted to formal models. It can be applied to organisms as well if the terms 'intrinsic' and 'extrinsic' are not interpreted as 'internal' and 'external' respectively but as 'dependent upon dynamics' and 'independent from dynamics' respectively, as introduced above. First-order intrinsic organismic factors are all material-energetic quantities generated by an organism that have an effect on its dynamics, such as the concentration of regulatory proteins, scleroproteins, hormones, ATP molecules etc. This category includes also environmental factors that the organism influences in order to improve the conditions of its life. In this sense regulated atmospheric humidity and room temperature are first-order intrinsic organismic factors as well.

First-order extrinsic organismic factors are all factors that influence but are not affected by an organism's dynamics. Those factors include initial conditions, such as the parental genetic constitution and the environment of a zygote at the time of its fertilization, fundamental laws of nature that constrain physicochemical processes, and environmental conditions that cannot be changed by organismic activity, such as gravitation, radioactivity, geological processes, solar activity, and the forms and quantities of available energy and matter. However, one of the most essential characteristics of life is that the borderline between first-order intrinsic and extrinsic factors is fluent. Especially during evolution of intelligence some of the extrinsic environmental factors just mentioned have been transformed to intrinsic ones. The idea of second-order factors applies also to organisms, as we will see shortly. However, real organisms do not obey the logic of self-organized dynamic systems for four reasons.

First, in sharp contrast to those formalisms, organisms are able to change the value of most quantities that in systems biology models are represented by parameters and independent variables, i.e. fixed quantities or constants that serve as rate coefficients or boundary conditions (Longo and Montévil 2012, 3). In contrast to these contemporary biological formalisms, in real organisms the number of extrinsic factors is only a tiny fraction of the number of all dynamic quantities which mutually determine their development. In other words, *in real organisms the number of first-order intrinsic factors exceeds by many times the number of first-order extrinsic ones.*

Second, during growth, regeneration, and readaptation of unicellular and multi-cellular organisms and in embryogenesis of the latter a vast array of new sorts of proteins is synthesized. This requires that the material constitution of each real organism is permanently subject to change. As a result, the structure of an organism is a sequence of permanently generated *new relations* between its own first-order intrinsic and first-order extrinsic factors. In current formalisms those relations are inappropriately represented by systems of *fixed* differential equations (e.g. formulas 2 and 3). As noted above, in current biological formalisms those systems of equations are second-order extrinsic factors. In contrast, even in primitive unicellular or mature multi-cellular organisms that do not undergo a process of radical regeneration or readaptation, relations between both kinds of first-order factors are themselves intrinsic factors. This is the case, since, on the one side, they are permanently varied by the organism's dynamics, even though only slightly, and, on the other side, they canalize this dynamics.

Embryonic processes display an even more radical dynamics. A system of differential equations representing the development of an embryo would have to undergo a transformation that is so radical that not only most of its parameters would have to be replaced by variables but also that formal system's structure—i.e., form and number of the equations themselves—would have to be subject to permanent radical variation until maturity is reached. To put it in a nutshell: *in real organisms second-order factors are necessarily intrinsic factors* or, in other words, *there are no second-order extrinsic factors in real organisms*. Even if a large part of an organism's dynamics is determined by an artificial cybernetic structure—think for example of humans with artificial hearts, brain pacemakers or even of a 'cyborg'—the organism is only alive so long as it is ruled by a second-order factor that permanently redefines the organism's relation to that non-organismic structure, i.e. to the second-order extrinsic factor that regulates the latter.

Third, to the extent to which organisms generate the relation between first-order intrinsic and first-order extrinsic factors they become able to autonomously interact with their environment. This is in a sharp contrast to systems studied by physics, including self-organized systems, the borders of which are determined either by a human experimenter or by an external physical factor, including chance. Organisms demonstrate a significant degree of organizational autonomy. The term 'self-organization' applies to them in a literal and not just metaphoric sense of 'self.' A self is "a dynamical process organized in such a way that it minimizes the probability that its organization will be lost" (Deacon and Koutroufinis 2014, 417). Selves autonomously create their relations to their environment. In 1909 Jakob von Uexküll introduced the term 'Umwelt' referring to those features of a living being's environment to which they are sensitive. Umwelt and self are two sides of the same coin. This is characterized by biosemiotician Kalevi Kull's translation of 'Umwelt' as "self-centered world" (2010).<sup>10</sup> The relations of selves to their Umwelts thereby correspond exactly to what in metaphysics is called 'internal relations' (see below).

Fourth, during growth and regeneration of unicellular and multi-cellular organisms and in embryogenesis of the latter a vast array of new sorts of molecules are synthesized. New sorts of molecules provide *new types* of intrinsic factors. As such, they need to be represented by *new dimensions of the state space*. In other words, only

continually growing state spaces would be able to represent embryogenesis, regeneration or growth of single cells and multi-cellular organisms.

#### 4.2. The logic of machines and its validity for contemporary biological formalisms

Contemporary biological formalisms follow the logic of regulation or control that characterizes man-made machines as well. The logic of both formal models and machines is based on a sharp logical distinction and strict operational segregation between intrinsic and extrinsic factors. In mechanical devices such as clock-works and combustion engines, this segregation is readily apparent. The intrinsic factors of first-order are the mutually constraining (and periodically recurrent) positions and movements of the moving parts, i.e. the state of the dynamical part of the machine at a certain point in time, for example the positions and movements of a piston. The first-order extrinsic factors include the material properties of the moving and non-moving machine parts and their fixed shapes, for example, the diameter and length of the cylinder of a combustion engine. The relation between all intrinsic and extrinsic factors of first-order constitutes the structure of the combustion engine, that is its second-order factor. A good example for visualizing a second-order factor is the relation between piston and cylinder. Is this relation an intrinsic or extrinsic one? Whereas the cylinder constrains movements and positions of the piston, i.e. the first-order intrinsic factors, the piston does not exert any kind of constraining influence on the cylinder. Thus the second-order factor is an extrinsic one. Cylinder wear caused by the piston's movements is, of course, the opposite of a constraining influence since it increases the range of the machine's (unintended) degrees of freedom. As a result, a worn-out machine can be found in more possible states than a sound one, which is what makes it unpredictable and unreliable. The logical dualism between (dynamic) intrinsic and (static) extrinsic factors of machines is paralleled by the descriptive dualism between *function* and *structure*. Whereas the structure determines the function, the latter is not allowed to influence the former because any such influences are unintended and thus degrade the machine's operation, i.e. increase its undesired degrees of freedom through wear.

Against the background of organismic logic, the logic of machines can be summarized as follows: *First*, in machines there is a given number of intrinsic and extrinsic factors, the latter exceeding by many times the former.

<sup>10</sup> The German word 'Umwelt' contains the terms 'um' meaning 'around' and 'Welt' meaning 'world.'

The exact opposite is the case for organisms. *Second*, the structure of a machine is a second-order extrinsic factor, since during the whole ‘lifetime’ of a machine, ideally, its structure is not influenced by its functioning at all, and therefore not subject to any variation. *Third*, since the number of intrinsic factors is fixed there is no generation of new *types* of intrinsic factors in machines. This allows the dynamics of all known real and abstract machines to be depicted in a state-space with a constant number of dimensions, i.e., in non-growing state-spaces.<sup>11</sup>

These three characteristic restrictions of machine-logic as well as the duality between function and structure apply equally to all kinds of machines: e.g. mechanical clockworks, steam engines, nuclear reactors, rocket and jet engines, cybernetic automata, quartz clocks, linear and cyclical particle accelerators, ancient Greek calculators, vacuum tube computers, quantum-computers, etc.

The conclusion drawn from these reflections is that *the logic of contemporary biological formalisms and self-organized dynamic systems theory is identical to the operational logic of machines*. This is not to claim that organisms are organized according machine-logic. It only means that the *models* in question obey this same mechanistic logic. Indeed, many of those models are regarded as paradigm examples of mechanistic thought.

### 4.3. Mechanistic systems ontology and the general logic of machines as expressed by *non-trivial* or *Turing machine*

The logic of machines, as it has been introduced in the last section, is not restricted to machines and specific formalisms. It applies also to most, if not all, theoretical models developed by physicists since the time of Galileo. In other words, it applies equally to models of dynamic and thermodynamic systems in or close to the state of thermodynamic equilibrium (e.g. harmonic oscillator, pendulum, solar system, gas in a closed container, solid bodies), models developed in electrodynamics and theories of special and general relativity, and to formal descriptions of self-organized open systems or dissipative structures, such as whirlpools, twist-ers, the red spot of Jupiter, snow-crystals, flames, Bénard

convection cells, granules on the sun’s surface, earth mantle convection, laser light, reaction-diffusion systems (e.g. Belousov-Zhabotinsky and similar reactions), soliton waves, and chaotic atmospheric phenomena.

The terms ‘mechanism’ and ‘mechanistic’ may be interpreted with a high theoretical precision if their etymological root—the Greek word ‘*mechané*’ (μηχανή) i.e. ‘machine’ is understood as referring to the most abstract description of all possible natural and artificial systems, including mathematical and other formalisms, obeying machine-logic: Heinz von Foerster’s *non-trivial machine* (2003, 139f.). The essential commonality between mathematical models in contemporary physics and biology and real (material) machines can be best demonstrated through the idea of non-trivial machine.

Von Foerster considers non-trivial machine to be identical with Turing machine (Ibid. 196). The term ‘Turing machine’ refers to a class of abstract devices or mathematical objects suggested by Alan Turing in 1937 in order to define a formal notion of computability, so called ‘Turing computability.’<sup>12</sup> Under the term ‘machine’ von Foerster understands “well-defined functional properties of an abstract entity rather than an assembly of cogwheels, buttons, and levers” (Ibid. 207f.). At any time the machine is in any one of a finite number of possible states. The transition from one state to another is controlled by conditions or rules specified for each specific machine. The term ‘machine’ thereby means a set of invariable transition rules.<sup>13</sup> Activity and change of state of a particular Turing machine are entirely determined by its transition rules, its current state, and its current input (Barber-Plummer 2013).

Von Foerster introduced the concept of the ‘non-trivial machine’ as opposed to that of ‘trivial machine.’ A particular trivial machine is essentially a particular invariable function or operator  $f$ , the current calculations of which do not depend on any past calculations at all. In contrast, a non-trivial machine is a system of mathematical functions the computations of which always depend on *all* computations it has ever carried out. The machine carries out two operations contemporaneously: First, at a time  $t$  depending on input  $x(t)$ , its corresponding internal state  $z(t)$ , and a number of constants  $c_i$ ,<sup>14</sup> it computes a particular output  $y(t)$  according an operator  $F$ :

<sup>11</sup> So called self-replicating machines do not constitute an exception to this claim. Formalisms of those abstract machines are grounded on von Neumann’s theory of cellular automata. Von Neumann could show that if certain externally set conditions (first-order extrinsic factors) are given, patterns of cellular activation emerge that copy themselves. Each self-replicating pattern is generated by a certain dynamic activity. Since cellular automata have a lattice with a fixed number of cells and each cell has a fixed number of possible states, all possible dynamics of such an automaton unfold in a state-space with a constant number of dimensions.

<sup>12</sup> A task is Turing computable if some Turing machine can carry it out.

<sup>13</sup> The rules of a particular Turing or non-trivial machine may be changed. Because of total lack of material reality, such an entirely abstract device is nothing but a specific set of abstract rules. Therefore, changing those rules would mean creating a new machine.

<sup>14</sup> In his writings, von Foerster does not mention any constants

$$y(t) = F[x(t), z(t), c_1]$$

(Formula 8)

Second, at the same time  $t$  also depending on input  $x(t)$ , its current internal state  $z(t)$ , and a number of additional constants  $c_2$ ,<sup>15</sup> it computes the *internal* state of the immediate future  $t+1$  according a transition rule or operator  $Z$ :

$$z(t+1) = Z[x(t), z(t), c_2]$$

(Formula 9)

So, at the next moment in time,  $t+1$ , both operations will be carried out under the influence of the varied internal state  $z(t+1)$ . The computation of the new output  $y(t+1)$  becomes dependent on the machines past computation and through it on all computations the machine has ever carried out. Thus a non-trivial machine is essentially different than a trivial one, since the modus operandi changes with every operation according an internal logic, the transition rule  $Z$ . It should be taken into account, however, that the abstract functions  $F$  and  $Z$  cannot be varied by the machine's operations.

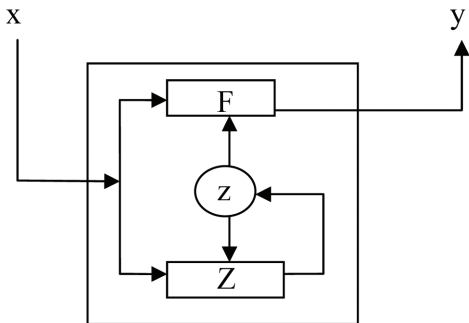

Fig. 3. Von Foerster's non-trivial machine.

In a non-trivial machine there are no higher-level transition rules computing the first-level transition rules. It can therefore be seen as a non-trivial machine of first-order. Conversely, a trivial machine may be seen as a zero-order non-trivial machine. Of course, one may think of non-trivial machines with one or more meta-levels of transition rules computing the lower level transition rules (Ibid. 152f.). All transition rules above the first level do not compute numeric results but other

transition rules. Although the number of levels may be arbitrarily high there is always a finite number of levels. This means, however, that in its highest level of operation any non-trivial machine is a trivial machine.

All Turing machines incorporate the same operational logic with three essential features:

1. As in the case for real machines, *in any non-trivial or Turing machine there is a sharp logical distinction and strict operational segregation between intrinsic and extrinsic causal factors*. The dependent or state variable  $z(t)$  is a first-order intrinsic factor. The input  $x(t)$  and the sets of constants  $c_1$  and  $c_2$  are first-order extrinsic factors. The constants  $c_1$  and  $c_2$  are parameters and  $x(t)$  is an independent variable.
2. The operators or abstract entities  $F$  and  $Z$  define the non-trivial machine's structure. They are second-order extrinsic factors, since they cannot be varied by the machine's operations, i.e., the computations of  $y(t)$  and  $z(t)$ .
3. Turing or non-trivial machines may be arbitrarily complex so that they have many different types of state variables  $z(t)$ .<sup>16</sup> In this case the machine's dynamics could be depicted only in a state space with a number of dimensions equal to the number of types of state variables. Non-trivial machines do not generate new types of first-order intrinsic factors, i.e. new types of state variables because this would require the variation of operators  $F$  and  $Z$ . For that reason *the dynamics of Turing machines can only be described in state-spaces with a fixed number of dimensions* representing the general types of their state variables  $z(t)$ .

Turing or non-trivial machines are abstract devices from which all current computers derive their architecture. All computations of real processes that can be simulated by our computers are based on Turing computable models of those processes. The computer-simulated pattern formation of embryogenetic development is determined by the machine's structure, i.e. the operators  $F$  and  $Z$ , but it is not contained or preformed in these entities. So, although a Turing machine's operators are abstract timeless entities, and thus universals or general types, they are essentially different from Aristotle's formal cause or form (eidos) or 'second substance.'

All organisms, including embryos, are not passive recipients of externally determined inputs but select through their purposeful agency, at least to a high

ci. If, however, the mathematical functions of the non-trivial machine are systems biological equations (see formulas 2, 3, and 5) they must entail independent variables and/or parameters, i.e., constants.

<sup>15</sup> See footnote 14.

<sup>16</sup> For example, the computation of the system consisting of formulas 2 and 3 requires a non-trivial machine that has two types of state variables  $z(t)$ :  $U(t)$  and  $V(t)$ .

degree, how their environments may influence them. Since inputs to organisms are to a significant degree determined by their interactions with their environment and a non-trivial machine can be recursively coupled with its environment as well (in this case  $x(t)$  would become to a certain degree a first-order intrinsic factor), it is worth raising the following question: Could a system of *mathematical general types F and Z*, consisting the structure of a non-trivial machine, be sufficient to model the final-state-directed dynamics that generates the general form of an organism at the end of its embryogenesis? Famously, Turing himself developed a formal model that attempted to explain how morphological patterning emerges in embryonic development (Turing 1952).

By design, a non-trivial machine does not transcend the primary differences distinguishing machine-logic from organismic logic for the following reasons. First, the machine's structure, represented by the operators F and Z, are second-order extrinsic factors, whereas second-order factors of organisms are intrinsic (see 4.1). Second, other than organisms, Turing machines do not generate *new types* of first-order intrinsic factors. This would require the variation of operators F and Z. But in non-trivial machines those essential changes can only be introduced by an external agent, since all operators of those machines are extrinsic factors and thus entities which do not succumb the machine's own dynamics. Third, since non-trivial machines do not generate new types of first-order intrinsic factors, their dynamics can only be described in state spaces with a fixed number of dimensions representing the general types of their dependent or state variables  $z(t)$  that represent the machine's internal state. In contrast, as noted above, the dynamics of all organisms, especially embryos and growing organisms, can only unfold in state spaces that progressively add dimensions. As a result, the dynamics of a real organism is for principal reasons non-Turing computable.

From the biophilosophical perspective of this essay there are two essential elements of Turing machine-logic. First, *sharp distinction between state variables (what is calculated) on the one hand and parameters, independent variables and operators (what is given from outside) on the other*. Second, *no generation of new general types of intrinsic causal factors, and thus restriction to a fixed state space*. This logic is entirely independent of the kind of forces and events that occur in a particular artificial, natural or entirely abstract system. In other words: Turing machine-logic is multiply realizable.

The logic of Turing or non-trivial machine is not restricted to theory of computation and abstract automata. From the time of Galileo to the present all formalisms of engineering sciences and most, if not all, formalisms of theoretical physics rely on this logic. They consider, at least implicitly, their systems as entities that can be described by models that abide by the abstract idea of machine, which is given its most general formulation as a non-trivial machine.

From this perspective, *an ontology can be described as a 'mechanistic systems ontology' or simply a 'mechanistic ontology' if it implicitly or explicitly assumes that the term 'system' refers to real entities the inner causality of which can, in principle, be explained by models obeying the logic of the Turing or non-trivial machine*. In this context 'in principle' means "if we had a perfect science (physics, biochemistry, biophysics etc.), knew all the details about the physical constitution of the organism and had unlimited computer power."

#### 4.4. Beyond neo-mechanistic thought in philosophy of biology

In the last two decades a new 'mechanical philosophy' (Craver 2013) has emerged in philosophy of science (Bechtel 2006, 2007; Glennan 2002; Machamer, Darden, Craver 2000). Due to the role that the concept of mechanism has played in the emergence of biological thought, the mechanistic program was mainly developed in philosophy of biology (Nicholson 2012, 153).

In his article, "The concept of mechanism in biology" Nicholson has provided a helpful distinction between three different meanings of the term 'mechanism' in biology:

1. 'Mechanicism' or 'mechanistic philosophy' is the philosophical position by which organisms may be conceived as "machines that can be completely explained in terms of the structure and interactions of their component parts" (Ibid. 153). Mechanicism is rooted in the philosophy of nature that emerged in the 17<sup>th</sup> century together with classical mechanics of Galilei, Descartes, Newton and others (Ibid.).
2. The 'machine mechanism' sense of 'mechanism' — that is the closest to the Greek term 'mechané' — "has traditionally been employed by biologists to describe machine-like systems, or rather, systems conceived in mechanical terms; that is, as stable assemblies of interacting parts arranged in such a way that their combined operation results in predetermined outcomes" (Ibid.).

3. The 'causal mechanism' sense of 'mechanism' refers to "[a] step-by-step explanation of the mode of operation of a causal process that gives rise to a phenomenon of interest" (Ibid.). In contrast to the first two meanings of 'mechanism' it "only acquired widespread currency in biology in the twentieth century" (Ibid. 154). According to Nicholson, "*it is the usage of the term that has become predominant today*" (Ibid., italics added). In other words: *in contemporary philosophy of biology the concept of 'mechanism' has become a synonym for 'causal mechanism' in the sense of 'causal mechanical explanation'* (Glennan 2002, S343f.) and is neither related to the idea of machine-mechanism of older biology that reduces organisms to complex machines nor to mechanistic philosophy of nature. Therefore, I refer to the third and most current interpretation of the term 'mechanism' as 'neo-mechanistic thought.' From the neo-mechanistic perspective, an explanation lies in the causal relationships between the parts of a mechanism. Central to this approach is the idea that a mechanism is a stable *complex system* that consists of a number of parts and activities the interaction of which gives rise to a behavior or function, i.e., to a process that is directed to a specific final state (Bechtel 2006, 2007; Craver 2013; Glennan 2002).

This functionalistic-teleological re-conception of the term 'mechanism' as mechanism *for some behavior/function* has given rise to two different *perspectivistic* interpretations of 'mechanism' or 'mechanical explanation' (Buzzoni 2016): Subjectivistic perspectivism, on the one hand, has been best expressed by Craver (2007, 2013). Because of the indissoluble connection of functional and mechanistic descriptions Craver considers the identification of functions as a crucial step in the discovery of mechanisms. The identification of functions within an organism or a cell depends, however, on one's perspective, i.e. scientific interests and goals. Thus, Craver claims, a researcher's subjective perspective determines what parts and activities of a living entity (cell, organism) will be seen as constitutive parts of a mechanism that explains a function of interest and which parts will be ignored (2013, 141-143, 155). Close to this position is Nicholson's appeal that we consider mechanisms not as real things but rather as conceptions that have merely heuristic value for scientific investigations (2012, 154, 158f., 162). Objectivistic perspectivism, on the other hand, assumes that there is an objective truth, or at least that different perspectives complement one the other in the sense that they contribute to a better knowledge of

the world. Buzzoni anchors this view in scientific experiments through operational-experimental devices in which we "compel nature to answer our questions" by starting a technical-mechanical process that takes place independently of our interests (2016, 419). Starting from this Buzzoni defines a mechanism as "the realization of potentialities that are already given in nature" (Ibid.423).

Both subjectivistic and objectivistic perspectivists anchor their theories in the conception of causal mechanism and not in the idea of machine-mechanism. It is however striking that neither the exponents of both neo-mechanistic approaches nor other supporters of neo-mechanistic thought in philosophy of biology deal with the highly developed mathematical models of causal mechanisms that have been introduced in systems biology. The principal limits of contemporary biological causal mechanisms do not become apparent so long as causal mechanisms are described in natural languages. Ordinary languages do not constrain our natural ability to create highly and even endlessly complex 'stories' about the entanglement of causally interdependent events. Nevertheless, problems become immediately obvious and even overwhelming as soon as we try to express the autonomy of even the simplest organism with a formal language that describes in a strict way quantitative relations, as it is the case with systems of differential equations and other formalisms of systems biology. In previous books, articles, and book chapters I have argued that while systems biological causal mechanisms are supportive of biotechnological manipulation of organisms they do not capture the autonomous agency of organisms (Deacon & Koutroufinis 2014; Koutroufinis 1996, 2009, 2014b; Koutroufinis & Wessel 2011). As I have shown in sections 4.2 and 4.3 of this paper, both causal mechanical explanations and machine-mechanisms abide by the same logic of causality that I describe as 'logic of machines.' Thus, although Nicholson's distinction between the two meanings of 'mechanism' as 'machine mechanism' and 'causal mechanism' (or causal mechanical explanation) is correct, at an abstract level of analysis, it can be shown that both machines and formal biological causal mechanism are special cases of the same abstract principle. All organisms, however, from the simplest bacterium to the most complex mammal, manifest an essentially different principle of causal organization if their autonomy is taken seriously (see section 4.1). Thus, the at the present highly renowned 'mechanical philosophy' cannot provide the basis for understanding the logic of causality

that exhibits the most essential feature of all organisms. In the 21<sup>st</sup> century the philosophy of organism must be established on the basis of an ontology that goes beyond the system-theoretical logic of contemporary mathematical biology that primarily serves the interests of biomedical and biotechnological industry. Only on the basis of a new ontology we will be able to conceive of organisms as autonomous agents, selves, and subjects that cannot be reduced to mere objects of scientific research.

## 5. Process logic—towards a process ontology for organismic causality

A common feature of all organisms is that whereas they permanently change their matter and energy they preserve their form or, if they grow or regenerate themselves, change it in a very specific way not reducible to the nature of their material and energetic elements. Organisms succeed in doing so because they generate second-order intrinsic factors. Baptiste's and Dupré's understanding of bacterial communities as self-stabilized systems in which entities of different levels of organization are involved (2013, 399) applies equally to organisms in general. They are stabilized processes which are not determined by one particular entity or by a particular type of entities, such as genes. "Questions of stabilization concern *fine-tuning* of the interactions between (different) entities through which their stability is optimized" (Ibid., italics added). Providing realistic formal models of organismic dynamics requires showing how such a *fine-tuning of quantities and rates*—which in current biological formalisms are represented by parameters and independent variables—can be generated by the dynamics itself. My main criticism of current systems biology is that it does not allow thinking of a system's dynamics as being able to autonomously produce variation of quantities and rates without destroying that system. This criticism pertains also to theoretical biology from the time of von Bertalanffy and Turing to the present. Those approaches operate with mathematical formalisms that parallel mechanistic ontology, as it is defined in section 4.3, thereby confining argumentation to the powerful but limited theoretical concept of a non-trivial machine.

There are two main reasons for developing a process ontology for biology. First, mechanistic ontology, as it is exemplified by the logic of non-trivial machine, cannot explain organismic causality due to the principal limitations of that logic. Second, substance ontolo-

gy, in its Aristotelian as well as in its Cartesian version, is even less able to do so. As noted in the introduction of this essay, Aristotelian ontology is rooted in a static conception of form (in the sense of 'eidos' that means species) or 'second substance' which does not harmonize with evolution of biological species. Cartesian ontology is rooted in the assumption that real beings can exist without any relations to each other—an equally unacceptable abstraction today.

Process ontologies are grounded on a philosophically elaborated definition of the term 'process' that considerably differs from the meaning, which is ascribed to this word in both its current scientific and everyday usage. I use the term 'organismic process' as meaning both embryogenesis and growth. The following definition of 'organismic process,' is general enough to capture the logic of organisms while remaining compatible with a wide range of process ontologies: *Organismic processes encompass a particular sort of coherent or self-organized events, distinguishable by two essential features: First, most factors that influence the development of an organismic process are generated by that process itself. Second, the structure of the relations between those factors is determined by the process itself.* Stated more technically, *an organismic process is a coherent event of which the second-order factor as well as most first-order factors are intrinsic.*

As a result organismic processes achieve autonomy by regulating their structure—i.e. the overall relation between its first order intrinsic and extrinsic factors—in such a way that this relation tends to stabilize itself. Due to their second order intrinsic factors, organismic processes realize a form of organization that can be labeled 'organizational closure.' This term is also used in a similar way by Maël Montévil and Matteo Mossio, who identify organizational closure as closure of constraints (2015). Finally I would like to put emphasis on the essential similarity between my approach and that of Giuseppe Longo and Maël Montévil in their article "The inert vs. the living state of matter" (2012). An organism's structure—its second-order intrinsic factor—is maintained at an "extended critical transition" through "global causal relations between levels of organization" (Ibid. 4).

The technical definition of 'organismic process' provided here does not contain any restrictions concerning the metaphysical status of the elementary causal factors evolved in the emergence of the process. Thus, it can serve as a fundamental assumption for comparing different process ontologies. In the following we will deal with Whitehead's process ontology, which I consider to

be sufficient for biology despite being rooted in metaphysical presuppositions strongly differing from the metaphysics of contemporary life sciences.

### 5.1. Process logic in Whitehead's metaphysics

Alfred North Whitehead (1861-1947) is often regarded as the most original innovator of the 20<sup>th</sup> century philosophy of nature and metaphysics. He is the best known representative of process philosophy. The basic premise of Whitehead's metaphysics is that all actual beings<sup>17</sup> in the universe are individual processes or groups of processes. They are not substances, either in Aristotle's sense of 'first substance' or in Descartes' sense of 'res extensa' or 'res cogitans.' Although his concept of 'process' was not explicitly developed for biology it has essential similarities to the definition of organismic process suggested above, probably because it was introduced against the background of all versions of mechanistic thought that were influential in the first half of the 20<sup>th</sup> century. Whitehead reformulated Aristotle's category of 'first substance' by introducing two different kinds of process: 'actual entities' or 'actual occasions' and 'societies.' The former are the most elementary actual beings of the universe—short-lived indivisible processes the spatiotemporal extension of which exhibit a large spectrum from quantum events to conscious brain processes. Societies are long-lived groups of interrelated actual occasions. According to Whitehead, everything which persists in space-time for a certain amount of time is the result of sequential manifestations of interconnected and interrelated actual occasions. Molecules, stones, planets, and physical events, such as chemical reactions and planetary motions, are described by Whitehead as societies. The most complex groups of actual occasions are living beings, which Whitehead describes as 'living societies.'

From this essay's perspective the central ideas of Whitehead's process philosophy are the following:

1. *Causa sui*: Actual occasions require an adequate environment to emerge. However, they are not just reactions to external conditions. In other words, they are not determined by facts which, according the above introduced terminology, could be described as 'extrinsic factors,' although they depend also on those facts. Whitehead emphasizes that an actual occasion is to a certain degree a creative being, since it "functions in respect to its own determination" (1978, 25).
2. *Processual teleology*: Because of their increasing ability to determine their own formation actual occasions exhibit final-state-directedness. Thus, they may be seen as teleological entities if, as in Aristotle's writings, 'telos' is taken to mean not only 'aim' but also 'final state.' However, in contrast to Aristotelian biology and substance ontologies, according which the final state of events is preformed in their formal cause (eidos), the final state of actual occasions emerges gradually as an actualization of intrinsic tendencies. Therefore, one may talk of a 'processual teleology' (Koutroufinis 2014a, 18; 2014b, 126-128).
3. *Internal relations with the environment*: Actual occasions are also intimately tied to their environment which consists of other already emerged processes. During their emergence certain features of their environment acquire a specific relevance while others become irrelevant. In this respect actual occasions are indissolubly related to a specific environment (1978, 73, 77, 80). The relations of Whiteheadian processes to their environments correspond exactly to what in metaphysics is called 'internal relations'—meaning relations without which neither of the related beings could physically exist (nor could their essential features be understood). Whitehead describes the internal relations between actual occasions as 'prehensions' (Ibid. 41; 1967, 234).
4. *Platonism*: Emerging actual occasions do not simply generate their own (intrinsic) causal factors but, moreover, factors which are embodiments of general types which Whitehead calls 'eternal objects' (1978, 22, 44). They are non-temporal abstract entities. The emergence of more complex actual occasions, all of which occur in living beings, consists in a sequence of consecutively actualized eternal objects (Ibid. 240-261). Because of their non-temporality, eternal objects necessarily pre-exist actual occasions which are spatiotemporally extended actual beings. According to Whitehead, eternal objects exist in order to provide actual occasions with their 'forms of definiteness' (Ibid. 22). He regarded his ontology as a renewal of Plato's metaphysics under the conditions of 20<sup>th</sup> century science (Ibid. 39). In order to characterize the relation between actual occasions

<sup>17</sup> I use the term 'actual being' as opposed to 'abstract being,' the later referring to general types or ideas.



- and eternal objects he explicitly employed Plato's central concept of 'participation' (methexis, μέθεξις): "The things which are temporal arise by their participation in the things which are eternal" (Ibid. 40).
5. *Mental-physical bipolarity*: Although eternal objects exist in order to provide actual entities with forms of definiteness, Whitehead considers them as entirely non physical beings existing in total separation and independence from the spatiotemporal or physical world (Ibid. 44; 1953, 197). Thus, spatiotemporally extended actual beings can participate in them only through a purely mental act. By 'purely mental act' I understand an act the description of which may lack any reference to facts of physical reality. I do not claim that those acts exist. All I am saying here is that Whitehead's Platonism requires the admission of those entities in his ontology. Thus, besides their internal relations to physically actualized beings (i.e. already emerged actual occasions and societies), actual occasions are internally related also to an entirely ideal reality. They are conceived of as *bipolar* entities: Actual occasions are indissolubly mental-physical beings: "Each actuality is essentially bipolar, physical and mental, and the physical inheritance is essentially accompanied by a conceptual reaction [...] always introducing emphasis, valuation, and purpose" (1978, 108). In *Adventures of Ideas* he expresses a similar view (177, 190, 245). Whitehead emphasizes that the 'mental pole' of processes has in addition to the conceptual also an experiential, qualitative, and thus subjective component (1978, 18). The relevance of eternal objects for an actual occasion's emergence is determined by that occasion's positive or negative subjective experiences of those objects (Ibid. 24, 212, 240, 254, 261).
  6. *Mental pole and second-order intrinsic causal factors*: With the introduction of eternal objects Whitehead brought back into modern philosophy of nature a concept similar to Aristotelian form (eidos) or 'second substance.' Still more, in opposition to 20<sup>th</sup> century mainstream philosophy of science, by considering abstract entities as non-temporal beings, Whitehead ascribed to general types ontological and not just conceptual being, thus following Aristotle's and Plato's universals realism. In Whitehead's thought, however, there is a crucial difference with respect to both ancient thinkers: Eternal objects are not able to determine the formation of an actual occasion. They can neither determine its final state nor decide the sequence in which they will be embodied in its emergence as its 'forms of definiteness.' Eter-

nal objects do not actively direct processes towards terminal states, as Aristotelian forms or formal causes do. It is the actual occasion itself—to be exact: its mental pole—which actively selects eternal objects as its 'forms of definiteness' and consecutively actualizes them until the process achieves its final definiteness, embodied by its finally selected eternal object (Ibid. 240-261). Thus, in contrast to both the ancient and medieval philosophy of nature, Whitehead did not consider ideal or abstract entities as active causes. In his ontology, *general types are not considered to be formal causes*, as they are in Aristotle's understanding of this term. That Whitehead did not identify 'forms of definiteness' (eternal object) with formal causes has severe ontological consequences. In sharp contrast to Aristotelian and Platonic metaphysics, in Whitehead's process ontology an actual occasion's essence cannot be identified with a non-spatiotemporal entity or universal, such as a particular species. *An actual occasion's essence is its mental pole*, which consists in a sequence of acts of selection among eternal objects, not determinable by those objects. In Whitehead's writings the mental pole can be understood as defining over and over again the causal relations between the emerging actual occasion, its physical environment, and the non-temporal reality of eternal objects (Ibid. 240-261). Thus, its role is similar to the role of second-order intrinsic factors in biological processes.

For two reasons Whitehead's understanding of process transcends both the logic of events the development of which is representable by trajectories in state spaces as well as the logic of Turing or non-trivial machine: First, in both these abstract constructions, subjective experience, which plays an important role in Whitehead's system, cannot be considered to have any causal relevance. Second, the logic of Turing machine and formalisms compatible with state spaces are based on the assumption that processes unfold within a fixed system of general types: the dimensions of the state space representing the fixed number of the non-trivial machine's various dependent or state variables  $z(t)$ . Since, during their formation, actual occasions generate their own type of organization by selecting new eternal objects and combining them to their forms of definiteness, they create new sorts of variables. Thus, they are not Turing computable events. They can be displayed only in state spaces the dimensions of which are transformed by the dynamics of the events that they (the state spaces) display. As a result, any understanding

of organism derivable from Whitehead's process ontology must deviate essentially from any consideration of organism based on mechanistic systems ontology. Of course, a Whiteheadian theory of organism must also essentially deviate from any understanding of organism rooted in substance ontologies, such as medieval or vitalistic biology.

There is however a conspicuous remnant of substance ontology in Whitehead's thought: Because they are non-temporal entities eternal objects are substantial beings that can neither be generated nor annihilated. Although they do not exist as their own ends but as potential forms of definiteness for processes, they are not in any way modified by those processes. In other words: The processuality of the spatiotemporal actuality depends considerably on beings that are not at all processual. This is an essential characteristic of substance ontologies.

Besides this 'incompleteness' of the metaphysical system there is a major problem that impedes the integration of Whitehead's process ontology to contemporary scientific reasoning: Whitehead's pan-experientialism. Although the hypothesis that each elementary actual being has a mental and a physical pole does not necessarily violate naturalism (Griffin 2014), with the exemption of a few quantum physicists, today's scientists are clearly unwilling to entertain this idea.

Nonetheless, I think that Whitehead has identified crucial dimensions that several process ontologies should share: internal relationality between process and environment, processual teleology, and separation of formal causes from non-temporal beings or general types. Since he thinks of actual occasions as acts that generate their own 'form of definiteness' or essence, an important achievement of his ontology is the *processualization of eidos or essence*.

## 6. Conclusion: towards an ontology for a new theoretical biology

Systems biology has been developed in the context of a close relationship with medical- pharmaceutical research and biotechnology. Its criterion of success is based on the extent to which it allows predictions of cellular behavior emerging under controlled laboratory conditions and not whether it explains how organismic behavior is generated. Systems biology is therefore based on assumptions that are consistent with a mechanistic systems ontology. Contemporary systems biological formalisms can be characterized as *mechanistic* in a specific sense: they obey a logic of causality

(causal factors) that is typical of man-made machines. The most abstract description of that logic is provided by Turing machine or von Foerster's non-trivial machine. From a process-centered perspective the essential features of the logic of non-trivial machine are the lack of second-order intrinsic factors, the strict distinction between first-order intrinsic and extrinsic factors, and the machine's inability to generate new general types of first-order intrinsic factors that is responsible for its inability to change the dimensionality of its state space. Real organisms are not limited by these restrictions and, on the contrary, exhibit the exact opposite property: they tend to change the dimensionality of the state space in which they function.

Dynamic entities escape Turing computability to the extent to which they generate new first-order intrinsic factors and transform the relations between first-order intrinsic and extrinsic factors, i.e., transform their second order intrinsic factor. The causality of organismic processes, such as growth and division of cells and morphogenesis, could be computed only by a non-trivial machines, the structure (the operators  $F$  and  $Z$ ) and the first-order extrinsic factors (the constants  $c_1$  and  $c_2$ ) of which could be modified by the operations that these very conditions ( $F$ ,  $Z$ ,  $c_1$ , and  $c_2$ ) make possible. This would require a Turing machine, the highest-order factors of which were intrinsic. This, however, violates the fundamental logic of Turing computability.

As a result, in contrast to linear and non-linear (self-organized) events studied by contemporary physics, the causality of organismic processes cannot be explained by analytical or numerical calculations because those processes are not Turing computable. The representability of Turing-computable events by formalisms, such as systems of differential equations and cellular automata, may be called 'compressibility' (Deacon and Koutroufinis 2014, 406). Since organisms cannot be adequately represented by Turing computable formalisms, their emergence and self-preservation are non compressible events. This suggests that organisms exhibit a form of complexity that cannot be captured by the concept of complexity used in physics and mathematics (Ibid. 415-418) which has been developed as a measure of incompressibility (Ibid. 407).

For these reasons, the logic of non-trivial machine, which is the logic of real and abstract machines and of current mathematical formalisms, is not an appropriate basis for explaining organismic causality. The transcendence of this logic can be achieved on the basis of

an ontology suitable for organismic dynamics. This ontology can be developed on the fundament of genuine understanding of process designed for capturing the logic of organismic causality.

Whitehead's process metaphysics transcends Turing machine-logic. The creation of a process ontology for biology on the basis of his metaphysics belongs to the field of what used to be termed 'theoretical biology.' Unfortunately, in the last decades, in biosciences the term 'theory' became a synonym for 'non experimental,' 'formal,' 'mathematical,' 'computational,' 'in silico,' 'artificial life' or 'dry lab.' This development has been counterproductive because it undermines the ability of biologists to examine the metaphysical assumptions, which bear their work and to identify the restrictions caused by them.

Nevertheless, the relation between today's systems biology and a prospective theoretical biology based on process ontology *need not be antagonistic*. Stuart Kauffman, one of the pioneers of systems biology, has contributed essential insights to a non mechanistic theory of organisms in recent years. His description of organisms as 'autonomous agents' (2000) and of the biosphere as a non Turing-computable system, the evolution of which can be depicted only in a growing state space (2000, 2013), represents a thoroughly process-centered biology. Provided that we are aware of the principal limitations of current systems biology, we can still use its highly developed formalisms as a way to approach organismic complexity. Those formalisms could be used to detect new patterns of non-linear dynamics, alien to contemporary dynamic systems theory: if we change the systems of coupled differential equations in order to convert even a few of the independent variables and parameters into variables we might discover new patterns of self-organized behavior in a system's state spaces, i.e., new kinds of attractors. Of course, in order to appropriately represent organismic causality we need to develop a theory of state spaces that can have a growing number of dimensions. This is not possible within the mathematical framework of contemporary dynamic systems theory. And yet, if we manage to develop those formalisms we will have taken an important step forward on the way to understanding organismic dynamics.

Another important task for a process ontologically oriented theoretical biology would be the development of a *qualitative mathematics* for representing organismic dynamics. Other than in systems biological formalisms the focus would be not on the computation of quantitative relations but on topological relations describing

the interconnectedness of causal factors belonging to different levels of organization. Interestingly enough this would be a revival of a philosophical intuition that originated with one of the pioneers of both mathematical theoretical biology and systems biology: Ludwig von Bertalanffy. In his book *Problems of Life* (first published in German 1949), Bertalanffy speaks of a new 'non-quantitative' or 'Gestalt mathematics' for biology (1952, 159), in which not quantity but rather the idea of form would come to occupy the central role.

## Acknowledgments

I would like to warmly thank Giuseppe Longo, Terrence W. Deacon, Jeremy Sherman, Paul-Antoine Miquel, Maël Montévil, Matteo Mossio, Ana M. Soto, and Carlos Sonnenschein for useful remarks on the early drafts of this paper. I owe particular thanks to Jeremy Sherman for carefully reading the final version. I am also grateful to the audience of the lecture series "Organismus als Maschine?" (Organism as a Machine?) at the Munich School of Philosophy for feedback on a presentation on this topic. I especially wish to thank Mariano Bizzarri for his invitation to contribute to the first issue of *Organisms*. Finally, I gratefully acknowledge the financial support from the University of California, Berkeley, where I wrote significant parts of this paper.

## References

- Aristotle 2008, *Physics*, Oxford University Press, Oxford, New York.
- 2006, *Metaphysics*, Oxford University Press, Oxford, New York.
- 2001, *Categories*, Virginia Tech., Blacksburg, VA.
- Baker R & Herman G, 1972, Simulation of organisms using a developmental model, parts I and II, *International Journal of Bio-Medical Computing*, vol. 3, no. 3, pp. 201-215 and 251-267.
- Baptiste E & Dupré J, 2013, Towards a processual microbial ontology, *Biology and Philosophy*, vol. 28, n. 2, pag. 379-404.
- Barker-Plummer D 2012 Turing Machines. *Stanford Encyclopedia of Philosophy*. Available from: <https://plato.stanford.edu/entries/turing-machine/> [6 March 2017]
- Bechtel, W, 2006, *Discovering cell mechanisms: The creation of modern cell biology*, Cambridge University Press, Cambridge.
- 2007 Biological mechanisms: Organized to maintain autonomy in: FC Boogerd, FJ Bruggerman JS Hofmeyr, HV Westerhoff et al., (eds), *Systems biology: Philosophical foundations*, pp. 269-302. Elsevier, New York.

- Bertalanffy L, 1952, *Problems of Life: An Evaluation of Modern Biological and Scientific Thought*, Harper, New York.
- Buzzoni M, 2016, Mechanisms, Experiments, and Theory Lad-ness: A Realist-Perspectivalist View, *Axiomathes*, vol. 26, pag. 411-427.
- Collier J, Monk N, Maini P & Lewis J, 1996, Pattern Formation by Lateral Inhibition with Feedback: a Mathematical Model of Delta-Notch Intercellular Signaling, *Journal of theoretical Biology*. Vol. 183, n. 4, pag. 429-446.
- Coombes S, 2009, The Geometry and Pigmentation of Sea-shells, Available from: <https://www.maths.nottingham.ac.uk/personal/sc/pdfs/Seashells09.pdf>. [6 March 2017]
- Craver C, 2007, *Explaining the brain: Mechanisms and the mosaic unity of neuroscience*, Oxford University Press, New York.
- 2013, Functions and mechanisms: a perspectivalist view, in: P Huneman, (ed), *Functions: selection and mechanisms*, pp. 133-158. Springer, Berlin.
- Deacon T, 2012, *Incomplete Nature*, W.W. Norton & Company, New York.
- Deacon T & Koutroufinis S, 2014, Information, complexity, and dynamic depth, *Information*, vol. 5, pag. 404-423.
- Descartes R, 1984, *Principles of Philosophy* (translated by V. Rodger), Reidel, Dodrecht, Boston, Lancaster.
- 1996, *Description du corps humaine* in C Adam & P. Tannery, (eds), *Ouvres de Descartes*, Vol. XI, Vrin, Paris.
- Devitt M, 2010, Species have (partly) intrinsic essences, *Philosophy of Science*, vol. 77, n. 5, pag. 648-661.
- Downward J, 2001, The ins and outs of signaling, *Nature*, vol. 411, pag. 759-762.
- Dupré J, 2012, *Processes of Life. Essays in the Philosophy of Biology*. Oxford University Press, Oxford.
- Ebeling W & Sokolov I, 2005, *Statistical Thermodynamics and Stochastic Theory of Nonequilibrium Systems*, World Scientific Publishing, New Jersey, London, Singapore.
- Editorial Team of *Nature*, 2010, Ten years of synergy, in: *Nature*, vol. 463, n. 7279, pag. 269-270.
- Elowitz M & Leibler S, 2000, A synthetic oscillatory network of transcriptional regulators. *Nature*, vol. 403, n. 6767, pag. 335-338.
- Emrich Š, 2007, *Comparison of Mathematical Models and Development of a Hybrid Approach for the Simulation and Forecast of Influenza Epidemics within Heterogeneous Populations*. Available from: [https://www.academia.edu/1094221/Comparison\\_of\\_Mathematical\\_Models\\_and\\_Development\\_of\\_a\\_Hybrid\\_Approach\\_for\\_the\\_Simulation\\_and\\_Forecast\\_of\\_Influenza\\_Epidemics\\_within\\_Heterogeneous](https://www.academia.edu/1094221/Comparison_of_Mathematical_Models_and_Development_of_a_Hybrid_Approach_for_the_Simulation_and_Forecast_of_Influenza_Epidemics_within_Heterogeneous) [6 March 2017]
- Falkner G & Falkner R, 2014, The Experience of Environmental Phosphate Fluctuations by Cyanobacteria: An Essay on the Teleological Feature of Physiological Adaptation, in Koutroufinis S. (ed), *Life and Process. Towards a New Biophilosophy*, pp.73-97. De Gruyter, Berlin.
- Ferrel J & Xiong W, 2001, Bistability in Cell Signaling: How to Make Continuous Processes Discontinuous, and Reversible Processes Irreversible, *Chaos*, vol. 11, n. 1, pag. 227-236.
- Foerster H, 2003, *Understanding Understanding: Essays on Cybernetics and Cognition*, Springer, New York, Berlin, Heidelberg.
- Gardner T, Cantor C & Collins J, 2000, Construction of a genetic toggle switch in *Escherichia coli*, *Nature*, vol. 403, n. 6767, pag. 339-342.
- Glennan, S, 2002, Rethinking mechanistic explanation, *Philosophy of Science*, vol. 69, n. 1, pag. S342-S353.
- Goldbeter A, 1997, *Biochemical Oscillations and Cellular Rhythms*, Cambridge University Press, Cambridge.
- Goodwin B, 1993, *How the Leopard Changed its Spots*, Phoenix, London.
- Griffin D, 2014, Evolution without Tears: A Third Way beyond Neo-Darwinism and Intelligent Design, in: Koutroufinis S (ed.), *Life and Process. Towards a New Biophilosophy*. pp. 255-273, De Gruyter, Berlin.
- Griffiths P, 2002, What is Innateness?, *Monist*, vol. 85, n. 1, pag. 70-85.
- Grimm V, Berger U, Bastiansen F, Eliassen S, Ginot V, Giske J, Goss-Custard J, Grand T, Heinz S & Huse G, 2006, A Standard Protocol for Describing Individual-Based and Agent-Based Models, *Ecological Modeling*, vol. 198, n. 1, pag. 115-126.
- Grimm V, Berger U, De Angelis D, Polhill G, Giske J & Railsback S, 2010, The ODD Protocol: A Review and First Update, *Ecological Modeling*, vol. 221, n. 23, pag. 2760-2768.
- Guidicelli F & Lewis J, 2004, The vertebrate segmentation clock, In: *Current Opinion in Genetics & Development*, vol. 14, n. 4, pag. 407-414.
- Gutmann M, 1995, Modelle als Mittel wissenschaftlicher Begriffsbildung, in: W Gutmann & M Weingarten, (eds), *Die Konstruktion der Organismen II. Struktur und Funktion*, pp. 15-35, Waldemar Kramer, Frankfurt/M.
- Ilachinski A, 2001, *Cellular Automata: A Discrete Universe*. World Scientific Publisher, New Jersey, London, Singapore, Hong Kong.
- Janich P & Weingarten M, 1999, *Wissenschaftstheorie der Biologie*, Wilhelm Fink, Munich.
- Karr J, Sanghvi J et al., 2012, A Whole-Cell Computational Model Predicts Phenotype from Genotype, *Cell*, vol. 150, n. 2, pag. 389-401. Available from: <http://www.sciencedirect.com/science/article/pii/S0092867412007763> [6 March 2017]
- Kauffman S, 1993, *The Origins of Order: Self-Organization and Selection in Evolution*, Oxford University Press, New York.
- 1995, *At Home in the Universe: The Search for Laws of Self-Organization and Complexity*, Oxford University Press, New York.
- 2000, *Investigations*, Oxford University Press, Oxford, New York.
- 2013, Evolution beyond Newton, Darwin, and Entailing Law, in: B Henning & A Scarfe (eds), *Beyond Mechanism. Putting Life Back Into Biology*, pp. 1-24. Lexington Books, Plymouth, UK.
- Kripke S, 1980, *Naming and Necessity*, Harvard University Press, Cambridge, MA.

- Koutroufinis S, 2014a, Introduction: The Need for a New Biophilosophy", in S Koutroufinis, (ed), *Life and Process. Towards a New Biophilosophy*, pp. 1-36, De Gruyter, Berlin.
- 2014b, Beyond Systems Theoretical Explanations of an Organism's Becoming: A Process Philosophical Approach, in S Koutroufinis, (ed), *Life and Process. Towards a New Biophilosophy*, pp. 99-132. De Gruyter, Berlin.
- 2013, Teleodynamics. A Neo-Naturalistic Conception of Organismic Teleology, in B Henning & A Scarfe (eds), *Beyond Mechanism. Putting Life Back Into Biology*, pp. 309-342, Lexington Books, Plymouth, UK.
- 2009, *Organismus als Prozess* (Habilitation Thesis, p. 569), the manuscript is available from the central library of the Technical University of Berlin, Germany.
- Koutroufinis S & Wessel A, 2011, Toward a Post-Physicalistic Concept of the Organism, *Annals of the History and Philosophy of Biology*, vol. 16, pag. 29-50.
- Kull K, 2010, Umwelt, in: P Cobley (ed), *The Routledge Companion to Semiotics*, pp. 348-349, Routledge, London.
- Lardon L, Merkey B, Martins S, Dötsch A, Picioreanu C, Kreft JU & Smets B, 2011, iDynoMiCS: next-generation individual-based modelling of biofilms, *Environmental Microbiology*, vol. 13, n. 9, pag. 2416-2434.
- Laubichler M 2005 Systemtheoretische Organismuskonzeptionen, in: U Krohs, G Toepfer, (eds), *Philosophie der Biologie*, pp. 109-124. Suhrkamp, Frankfurt/M.
- Longo G, Montévil M, 2012, The inert vs. the living state of matter: extended criticality, time geometry, anti-entropy – an overview, *Frontiers in Physiology*, vol. 3, n. 39, pag. 1-8.
- Machamer P, Darden L & Craver CF, 2000, Thinking about mechanisms, *Philosophy of Science*, vol. 67, n. 1, pag. 1-25.
- MacLeod M & Nersessian N, 2013, Building Simulations from the Ground Up: Modelling and Theory in Systems Biology, *Philosophy of Science*, vol. 80, n. 4, pag. 533-556.
- Meinhardt H, 2003, *The Algorithmic Beauty of Sea Shells*, Springer, Berlin, Heidelberg, New York.
- Meinhardt H & Gierer A, 2000, Pattern formation by local self-activation and lateral inhibition, *BioEssays*, vol. 22, n. 8, pag. 753-760.
- Merkey B, Lardon L, Seoane J, Kreft JU & Smets B, 2011, Growth dependence of conjugation explains limited plasmid invasion in biofilms: an individual-based modelling study, *Environmental Microbiology*, vol. 13, n. 9, pag. 2435-2452.
- Montévil M & Mossio M, 2015, Biological organization as closure of constraints, *Journal of Theoretical Biology*, vol. 372, pag. 179-191.
- Murray J, 1993, *Mathematical Biology*, Springer, New York, Berlin, Heidelberg.
- Nicholson D, 2012, The concept of mechanism in biology, *Studies in History and Philosophy of Biological and Biomedical Sciences*, vol. 43, n. 1, pag. 152-163.
- Nijhout F, 2003, Gradients, Diffusion, and Genes in Pattern Formation, in: G Müller & S Newman, (eds), *Origination of Organismal Form*, The MIT Press, Cambridge MA, London, pp. 166-181
- Noble D, 2006, *Music of Life. Biology Beyond the Genome*, Oxford University Press, Oxford, New York.
- Oyama S, Griffiths P & Gray R, 2001, *Cycles of Contingency: Developmental Systems and Evolution*, MIT Press, Cambridge, MA.
- Packard A, 2001, A 'neural' net that can be seen with the naked eye, in: W Backhaus, (ed), *Neuronal Coding of Perceptual Systems*, World Scientific Publisher, Singapore, New Jersey, London, Hong Kong, pp. 397-402.
- Panning T, Watson, L, Shaffer C & Tyson J, 2007, A Mathematical Programming Formulation for the Budding Yeast Cell Cycle, *SIMULATION*, vol. 83, n. 7, pag. 497-514
- Peak D, West J, Messinger S & Mott K, 2004, Evidence for complex, collective dynamics and emergent, distributed computation in plants, *Proceedings of the National Academy of Science (PNAS)*, vol. 101, n.4, pag. 918-922.
- Putnam H, 1975, *Mind, Language and Reality*, Cambridge University Press, Cambridge.
- Rothschuh K, 1968, *Physiologie. Der Wandel ihrer Konzepte, Probleme und Methoden vom 16. bis 19. Jahrhundert*, Alber, Freiburg, Munich.
- Savageau M, Coelho P, Fasani R, Tolla D & Salvador A, 2009, Phenotypes and tolerances in the design space of biochemical systems, *Proceedings of the National Academy of Science (PNAS)*, vol. 106, n 16, pag. 6435-6440.
- Savageau M, 1988, Introduction to S-systems and the underlying power-law formalism. *Mathematical and Computer Modelling*, vol. 11, pag. 546-551.
- Sober E, 1980, Evolution, Population Thinking and Essentialism, *Philosophy of Science*, vol. 47, n. 3, pag. 350-383.
- Turing A, 1952, The Chemical Basis of Morphogenesis, *Philosophical Transactions of the Royal Society of London (Series B)*, vol. 237, n. 641, pag. 37-72.
- Tyson J, Chen K & Novak B, 2003, Sniffer, Buzzers, Toogles and Blinkers: Dynamics of Regulatory and Signaling Pathways in the Cell, *Current Opinion in Cell Biology*, vol. 15, n 3, pag. 221-231.
- Van Hoek MJ, 2008, *Evolutionary Dynamics of Metabolic Adaptation*, Utrecht: Utrecht University.
- Van der Wal A, Tecon R, Kreft JU, Mooij WM & Leveau JH, 2013, Explaining Bacterial Dispersion on Leaf Surfaces with an Individual-Based Model (PHYLLOSIM), *PLoS ONE*, e75633. Available from: <http://journals.plos.org/plosone/article?id=10.1371/journal.pone.0075633> [6 March 2017]
- Voit EO, 2000, *Computational Analysis of Biochemical Systems*, Cambridge University Press: Cambridge, New York.
- 2013, Biochemical Systems Theory: A Review. *ISRN Biomathematics* 2013, article ID 897658. Available from: <https://www.hindawi.com/journals/isrn/2013/897658/> [6 March 2017]
- Voit EO & Schubauer-Berigan M, 1998, The role of canonical modeling as a unifying framework for ecological and human risk assessment, in M Newman & Stojan, C, (eds), *Risk Assessment: Logic and Measurement*, pp. 101-139. Ann Arbor Press, Chelsea, Mich.

- Waddington C & Cowe J, 1969, Computer simulations of a molluscan pigmentation pattern, *Journal of Theoretical Biology*, vol. 25, pag. 219-225.
- Whitehead AN, 1953, *Science and the Modern World*, At the University Press, Cambridge.
- 1958, *Function of Reason*, Beacon Press, Boston.
  - 1967, *Adventures of Ideas*, Free Press, New York.
  - 1978, *Process and Reality*, Free Press, New York.
  - 2007, *Religion in the Making*, Fordham University Press, New York.
- Wiggins D, 1980, *Sameness and Substance*, Blackwell, Oxford.
- Wolfram S, 1984, Cellular automata as models for complexity *Nature*, vol. 311, pag. 419.